

# XML message for SEPA Credit Transfer Initiation Implementation Guidelines for the Netherlands



## **Disclaimer**

These guidelines may be subject to changes. Utmost care has been taken to ensure the information in this publication is accurate. However, the Dutch Payments Association shall not be liable for any errors, inaccuracies or omissions in the contents of this publication.

Version 7.0 – February 2013

---

## Contents

Introduction.....	3
Change History .....	4
Coverage.....	5
Use of these Guidelines.....	6
Character set .....	7
Message Structure.....	8
Message items description.....	12
Annex A Detailed message item overview .....	55
Annex B Clieop03 equivalent.....	62
Annex C Rulebook attribute equivalent .....	63
Annex D Overview ISO codes .....	64
Annex E Generic ISO message Items .....	65
Annex F Example message .....	73
Annex G Overview of applicable usage rules .....	77

## Introduction

This document describes the Implementation Guidelines for the XML Customer Credit Transfer Initiation message ISO20022 - “pain.001.001.03” in the Netherlands.

The purpose of these Implementation Guidelines is to provide guidance on the use of the SEPA Credit Transfer Initiation Message sent to banks residing in The Netherlands. These guidelines are compliant with:

- ISO20022 – Message Definition Report edition September 2009
- EPC - SEPA Credit Transfer Scheme Customer-to-Bank Implementation Guidelines, version 7.0, issued 30 November 2012 (EPC132-08)

These guidelines can be used as of the date of release and replace all previous versions. No changes will be made anymore to any previous versions.

These Implementation Guidelines have been developed by the Dutch banks together with the Dutch Payments Association (‘Betaalvereniging Nederland’).

The utmost has been done to make sure the information in this publication is correct. However, the Dutch Payments Association can by no means be held responsible for any loss or damage incurred to any incorrect or incomplete information as described in this publication.

Please contact your bank for any further information.

## Change History

New releases of the Implementation Guidelines are published on a regular basis, based on new versions of the underlying standards or to provide clarification where required. The following table provides an overview of the versions released to date.

Version	Date
2.0	October 2010
2.1	February 2011
5.0	January 2012
6.0	March 2012
7.0	February 2013

Versions are numbered x.y(.z). As from this version it has been decided to align the version numbering with that of the implementation guidelines as published by the EPC regarding the SCT. In case a new version of this document is released (mainly as a result of clarifications or error corrections) before the EPC releases a new version of the implementation guidelines, an additional minor release indicator z will be added (e.g. 7.0.1 for an updated version of this document).

The following additions and modifications have been made in version 7.0 compared to version 6.0:

Index	Description	Type <sup>1</sup>
2.21	Either BIC or 'Other/Identification' must be used. When 'Other/Identification' is used, only 'NOTPROVIDED' is allowed in 'Identification'. The BIC is mandatory for EU/EEA cross border transactions until 31 January 2016.	CHAN
2.21	Advise EPC usage rules effective per 1 January 2013 for NL domestic payments.	CHAN

<sup>1</sup> CHAN: Change in further alignment with the Rulebook content or alignment with Dutch regulation/Dutch interbank agreements

## Coverage

The Customer SEPA Credit Transfer Initiation message is sent by the initiating party to the debtor bank. It is used to request movement of funds from the debtor account to a creditor account.

The Customer SEPA Credit Transfer Initiation message is used to exchange:

- One or more SEPA Credit Transfer instructions;
- Payment transactions that result in a single entry on the debtor account per individual transaction or a batch entry for all transactions in a payment;

The message can be used in a direct or a relay scenario:

- In a direct scenario, the message is sent directly to the debtor bank. The debtor bank is the account servicer of the debtor;
- In a relay scenario, the message is sent to a forwarding party. The forwarding party acts as a concentrating financial institution. It will forward the Customer SEPA Credit Transfer message to the debtor bank.

The message can also be used by an initiating party that has been mandated to send a payment instruction on behalf of the debtor. This caters for example for the scenario of a payments factory initiating all payments on behalf of a large corporate, or an entity administering the salary payments of a company's employees.

## Use of these Guidelines

Each item of the CreditTransferInitiation message is referred to the corresponding index of the item in the UNIFI (ISO 20022) Message Definition Report for Payment Standards – Initiation. This Report can be found on [www.iso20022.org](http://www.iso20022.org), under “Catalogue of ISO 20022 messages”, with “pain.001.001.03” as reference ([www.iso20022.org/documents/general/Payments\\_Maintenance\\_2009.zip](http://www.iso20022.org/documents/general/Payments_Maintenance_2009.zip)).

This document is based upon the UNIFI (ISO 20022) XML message standards and the SEPA Credit Transfer scheme customer-to-bank implementation guidelines. These implementation guidelines can be found on: [www.europeanpaymentscouncil.eu/content.cfm?page=sepa\\_credit\\_transfer](http://www.europeanpaymentscouncil.eu/content.cfm?page=sepa_credit_transfer). In addition the Dutch specific usage rules are added.

The description of each message item contains:

Index	Number that refers to the corresponding description in the UNIFI (ISO 20022) Message Definition Report for Payment Standards – Initiation
XML Tag	Short name that identifies an element within an XML message, that is put between brackets, e.g. <Amount>
Occurrences	<p>This indicates whether an element is optional or mandatory and how many times the element can be repeated. The number of occurrences is shown in square brackets</p> <p>For example:</p> <p>[0..1] shows that the element can be present 0 times or 1 time. The element is optional</p> <p>[1..1] shows that the element can only be present 1 time. The element is mandatory</p> <p>[1..n] shows that the element is mandatory and can be present 1 to n times</p> <p>An element, that is part of a block of elements, is mandatory as far as the block it is part of, is present in the message.</p> <p>If only one of several elements may be present, this is indicated by {OR ... OR} before the elements concerned.</p>
Format	This specifies the permitted values and format

Definition	This contains the definition of the message block or element
Usage ISO	Additional info how this element must be used according to the ISO standards
Usage EPC	Any specific rules that could impact the presence or the values of an element as set in the SEPA Credit Transfer scheme customer-to-bank implementation guidelines
Usage NL	Any additional rules as set by the Dutch Payments Association specific for the Dutch community

## Character set

The UTF-8 character encoding standard must be used in the UNIFI messages.

The Latin character set, commonly used in international communication, must be used.

It contains the following characters:

a b c d e f g h i j k l m n o p q r s t u v w x y z

A B C D E F G H I J K L M N O P Q R S T U V W X Y Z

0 1 2 3 4 5 6 7 8 9

/ - ? : ( ) . , ' +

Space

Note: the above is about characters that can be used within the tags. For the message itself also other characters (especially < and >) can be used.

## Message Structure

The description of the XML document models can be found in a number of schemes. A specific description language (XSD) is used in those schemes. The schemes make it possible to give a description of the tags in the document, the structure and sequence of those elements (hierarchy of tags) as well as the codes which are allowed for some specific data, the number of possible cases, the obligatory or optional character of some of the data, etc.

The general XSD for pain.001.001.03 can be downloaded from:

[www.iso20022.org](http://www.iso20022.org), under “Catalogue of ISO 20022 messages”, with “pain.001.001.03” as reference ([www.iso20022.org/documents/messages/pain/schemas/pain.001.001.03.zip](http://www.iso20022.org/documents/messages/pain/schemas/pain.001.001.03.zip)).

A file containing an XML- pain.001.001.03 message has the following structure<sup>2</sup>:

```
<?xml version="1.0" encoding="UTF-8"?>
<Document xmlns="urn:iso:std:iso:20022:tech:xsd:pain.001.001.03"
xmlns:xsi="http://www.w3.org/2001/XMLSchema-instance">
    <CstmrCdtTrfInitn>
        message content...
    </CstmrCdtTrfInitn>
</Document>
```

A file must contain one single Document (envelope), with one single XML message in it. See example in Annex F Example message.

The support of multiple documents per file must be agreed bilaterally with your bank.

The Customer Credit Transfer Initiation message is composed of 3 building blocks:

- A. **Group Header:** This building block is mandatory and present once. It contains elements such as Message Identification, Creation Date and Time, Grouping Indicator.

---

<sup>2</sup> for an XML-pain.001.001.03 message example go to:

<http://www.betaalvereniging.nl/wp-uploads/2013/01/BvN-pain.001.001.03-example-message.xml>



- B. **Payment Information:** This building block is mandatory and repetitive. It contains besides elements related to the debit side of the transaction, such as Debtor and Payment Type Information, also one or several Transaction Information Blocks.
- C. **Transaction Information:** This building block is mandatory and repetitive. It contains, amongst others, elements related to the credit side of the transaction, such as Creditor and Remittance Information.

The number of occurrences of Payment Information Block and Transaction Information Block within a message is indicated by the Grouping field in the Group Header. Only the following combination can be used :

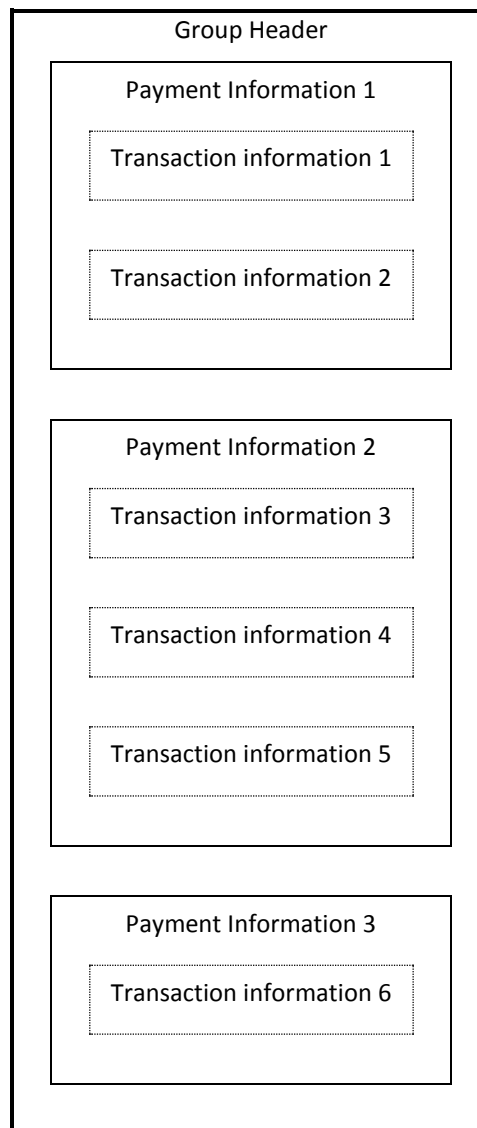

A detailed view on the structure of a Credit Transfer Initiation Message is presented below.

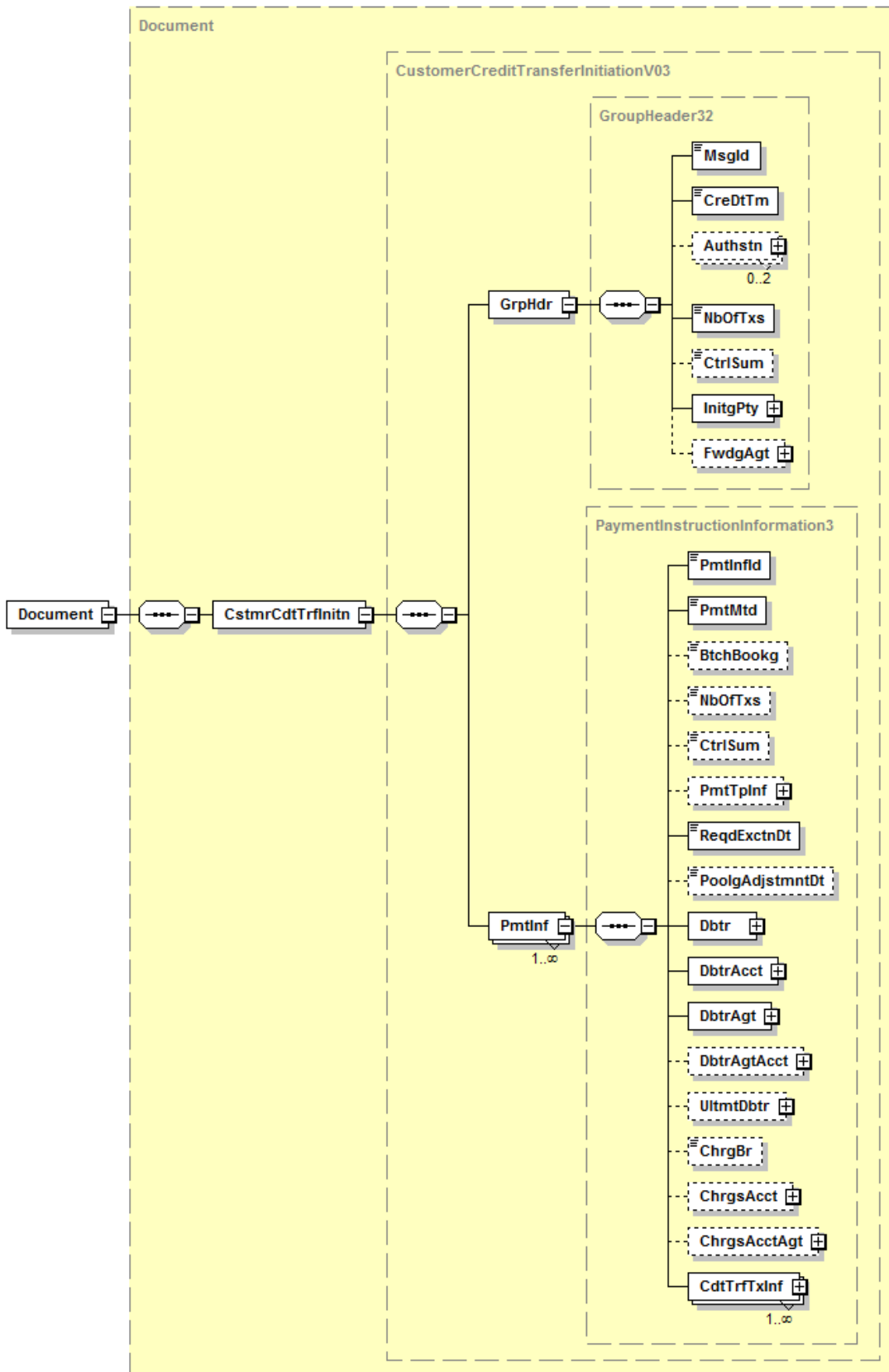

Legend:

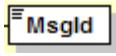

Box with full-line is a **mandatory** Message Element

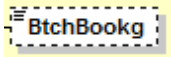

Box with dotted line is an **optional** Message Element

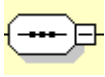

The Child Elements must appear in the **sequence** mentioned



Only one of the possible Child Elements may be present (choice)

## Message items description

### 0.0 CustomerCreditTransferInitiation

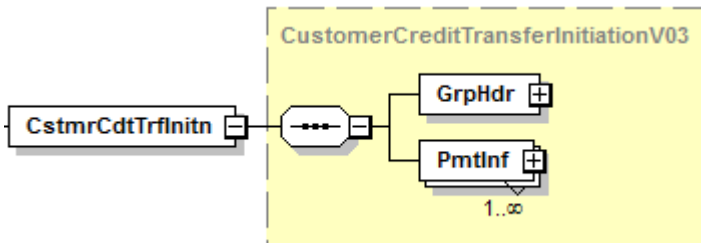

XML Tag: <CstmrCdtTrfInittn>

Occurrence: [1..1]

Definition: Root element

Type: The CustomerCreditTransferInitiation block is composed of the following CustomerCreditTransferInitiationV03 element(s):

Index	Or	MessageItem	<XMLTag>	Mult.	Represent./Type
1.0		GroupHeader	<GrpHdr>	[1..1]	+
2.0		PaymentInformation	<PmtInf >	[1..n]	+

### 1.0 GroupHeader

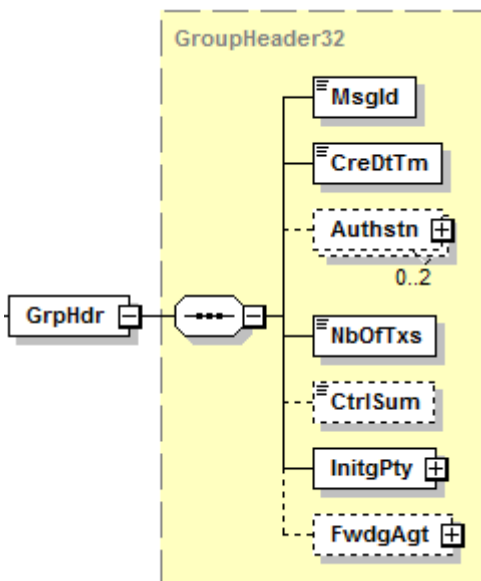

XML Tag: <GrpHdr>

Occurrence: [1..1]

Definition: Set of characteristics shared by all individual transactions included in the message.

Type: The GroupHeader block is composed of the following GroupHeader32 element(s):

Index	Or	MessageItem	<XMLTag>	Mult.	Represent./Type
1.1		MessageIdentification	<MsgId>	[1..1]	Text
1.2		CreationDateTime	<CreDtTm>	[1..1]	DateTime
1.3		Authorisation	<Authstn>	[0..2]	
1.6		NumberOfTransactions	<NbOfTxs>	[1..1]	Text
1.7		ControlSum	<CtrlSum>	[0..1]	Quantity
1.8		InitiatingParty	<InitgPty>	[1..1]	+
1.9		ForwardingAgent	<FwdgAgt>	[0..1]	+

### 1.1 MessageIdentification

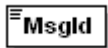

XML Tag: <MsgId>

Occurrence: [1..1]

Definition: Point to point reference, as assigned by the instructing party, and sent to the next party in the chain to unambiguously identify the message.

Usage ISO: The instructing party has to make sure that MessageIdentification is unique per instructed party for a pre-agreed period.

Data Type: Max35Text

Format: maxLength: 35  
minLength: 1

### 1.2 CreationDateTime

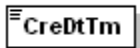

XML Tag: <CreDtTm>

Occurrence: [1..1]

Definition: Date and time at which the message was created.

Data Type: ISODateTime

### 1.3 Authorisation

Message Element that is not part of the addendum for the IG SCT Netherlands but is available for future use in a SEPA AOS.

## 1.4 Code

Message Element that is not to be used in SEPA Payments for NL.

## 1.5 Proprietary

Message Element that is not to be used in SEPA Payments for NL.

## 1.6 NumberOfTransactions

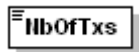

XML Tag: <NbOfTxS>  
 Occurrence: [1..1]  
 Definition: Number of individual transactions contained in the message.  
 Data Type: Max15NumericText  
 Format: [0-9]{1,15}

## 1.7 ControlSum

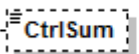

XML Tag: <CtrlSum>  
 Occurrence: [0..1]  
 Definition: Total of all individual amounts included in the message.  
 Data Type: DecimalNumber  
 Format: fractionDigits: 17  
 totalDigits: 18  
 Usage NL: Total of all individual amounts included in the message.

## 1.8 InitiatingParty

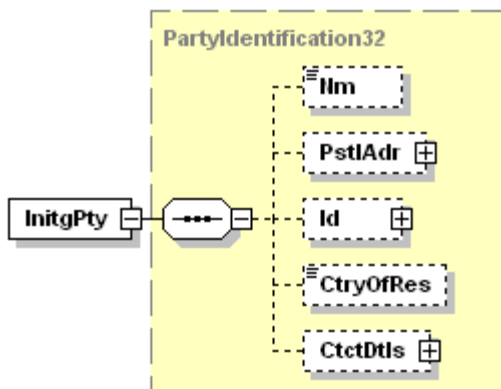

XML Tag: <InitgPty>

Occurrence: [1..1]

Definition: Party that initiates the payment.

Usage ISO: This can either be the debtor or the party that initiates the credit transfer on behalf of the debtor.

Type: This message item is composed of the following PartyIdentification32 element(s):

MessageItem	<XMLTag>	Mult.	Represent./Type
Name	<Nm>	[0..1]	Text
PostalAddress	<PstlAdr>	[0..1]	
Identification	<Id>	[0..1]	
CountryOfResidence	<CtryOfRes>	[0..1]	Code
ContactDetails	<CtctDtls>	[0..1]	

Usage EPC: 'Name' is limited to 70 characters in length.

'OrganisationIdentification': Either 'BIC or BEI' or one occurrence of 'Other' is allowed.

'PrivateIdentification': Either 'Date and Place of Birth' or one occurrence of 'Other' is allowed.

## 1.9 ForwardingAgent

Message Element that is not part of the addendum for the IG SCT Netherlands but is available for future use in a SEPA AOS.

## 2.0 PaymentInformation

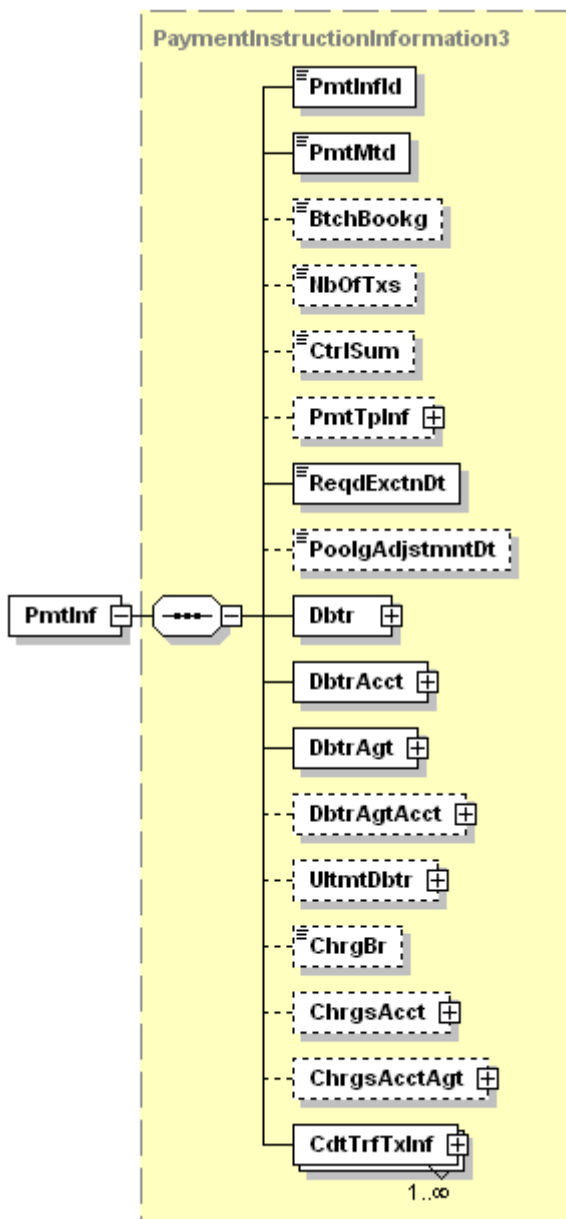

XML Tag: <PmtInf>

Occurrence: [1..n]

Definition: Set of characteristics that applies to the debit side of the payment transactions included in the credit transfer initiation.

Type: The PaymentInformation block is composed of the following PaymentInstructionInformation3 element(s):

Index	MessageItem	<XMLTag>	Mult.	Represent./Type
2.1	PaymentInformationIdentification	<PmtInfd>	[1..1]	Text



2.2	PaymentMethod	<PmtMtd>	[1..1]	Code
2.3	BatchBooking	<BtchBookg>	[0..1]	Indicator
2.4	NumberOfTransactions	<NbOfTxs>	[0..1]	Text
2.5	ControlSum	<CtrlSum>	[0..1]	Quantity
2.6	PaymentTypeInformation	<PmtTpInf>	[0..1]	
2.17	RequestedExecutionDate	<ReqdExctnDt>	[1..1]	Date
2.18	PoolingAdjustmentDate	<PoolgAdjstmntDt>	[0..1]	Date
2.19	Debtor	<Dbtr>	[1..1]	+
2.20	DebtorAccount	<DbtrAcct>	[1..1]	+
2.21	DebtorAgent	<DbtrAgt>	[1..1]	+
2.22	DebtorAgentAccount	<DbtrAgtAcct>	[0..1]	+
2.23	UltimateDebtor	<UltmtDbtr>	[0..1]	+
2.24	ChargeBearer	<ChrgBr>	[0..1]	Code
2.25	ChargesAccount	<ChrgsAcct>	[0..1]	+
2.26	ChargesAccountAgent	<ChrgsAcctAgt>	[0..1]	+
2.27	CreditTransferTransactionInformation	<CdtTrfTxInf>	[1..n]	

## 2.1 PaymentInformationIdentification

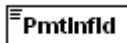

XML Tag: <PmtInflId>

Occurrence: [1..1]

Definition: Unique identification, as assigned by a sending party, to unambiguously identify the payment information group within the message.

Data Type: Max35Text

Format: maxLength: 35

minLength: 1

## 2.2 PaymentMethod

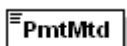

XML Tag: <PmtMtd>

Occurrence: [1..1]

Definition: Specifies the means of payment that will be used to move the amount of money.

Data Type: Code  
Usage EPC: Only 'TRF' is allowed.

Code	Name	Definition
TRF	Credit Transfer	Transfer of an amount of money in the books of the account servicer.

### 2.3 BatchBooking

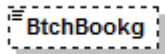

XML Tag: <BtchBookg>  
 Occurrence: [0..1]  
 Definition: Identifies whether a single entry per individual transaction or a batch entry for the sum of the amounts of all transactions within the group of a message is requested.  
 Usage ISO: Batch booking is used to request and not order a possible batch booking.  
 Data Type: One of the following BatchBookingIndicator values must be used:  
 MeaningWhenTrue: Identifies that a batch entry for the sum of the amounts of all transactions in the message is requested.  
 MeaningWhenFalse: Identifies that a single entry for each of the transactions in the message is requested.  
 Usage EPC: If present and contains 'true', batch booking is requested. If present and contains 'false', booking per transaction is requested.  
 If element is not present, preagreed customer-to-bank conditions apply.

### 2.4 NumberOfTransactions

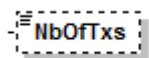

XML Tag: <NbOfTxs>  
 Occurrence: [0..1]  
 Definition: Number of individual transactions contained in the payment information group.  
 Data Type: Max15NumericText  
 Format: [0-9]{1,15}

## 2.5 ControlSum



XML Tag: <CtrlSum>  
 Occurrence: [0..1]  
 Definition: Total of all individual amounts included in the group.  
 Data Type: DecimalNumber  
 Format: fractionDigits: 17  
 totalDigits: 18  
 Usage NL: Total of all individual amounts included in the group (under index 2.0).

## 2.6 PaymentTypeInformation

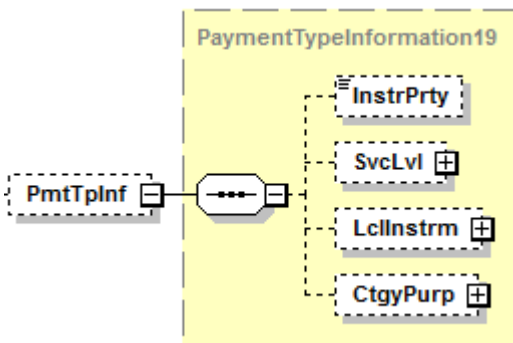

XML Tag: <PmtTpInf>  
 Occurrence: [0..1]  
 Definition: Set of elements used to further specify the type of transaction.  
 Type: This message item is composed of the following PaymentTypeInformation19 element(s):

Index	MessageItem	<XMLTag>	Mult.	Represent./Type
2.7	InstructionPriority	<InstrPrty>	[0..1]	Code
2.8	ServiceLevel	<SvcLvl>	[0..1]	
2.11	LocalInstrument	<LclInstrm>	[0..1]	
2.14	CategoryPurpose	<CtgyPurp>	[0..1]	

Usage EPC: If used, it is recommended to be used only at 'Payment Information' level and not at 'Credit Transfer Transaction Information' level. When Instruction Priority is to be used, 'Payment Type Information' must be present at 'Payment Information' level.

## 2.7 InstructionPriority

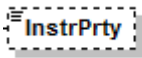

XML Tag: <InstrPrty>

Occurrence: [0..1]

Definition: Indicator of the urgency or order of importance that the instructing party would like the instructed party to apply to the processing of the instruction.

Data Type: Code

When this message item is present, one of the following Priority2Code values must be used:

Code	Name	Definition
HIGH	High	Priority level is high
NORM	Normal	Priority level is normal

Usage EPC: If present, pre-agreed customer-tobank conditions apply.

## 2.8 ServiceLevel

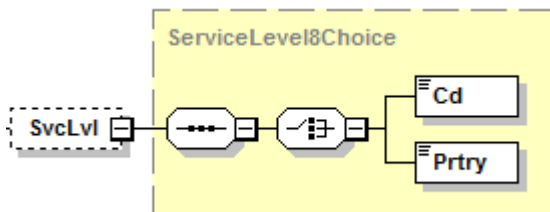

XML Tag: <SvcLvl>

Occurrence: [0..1]

Definition: Agreement under which or rules under which the transaction should be processed.

Type: This message item is composed of one of the following ServiceLevel8Choice element(s):

Index	Or	MessageItem	<XMLTag>	Mult.	Represent./Type
2.9	{Or	Code	<Cd>	[1..1]	Code
2.10	Or}	Proprietary	<Prtry>	[1..1]	Text

Usage EPC: Usage is recommended.

## 2.9 Code

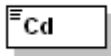

XML Tag: <Cd>

Occurrence: [1..1]

This message item is part of choice 2.8 ServiceLevel.

Definition: Specifies a pre-agreed service or level of service between the parties, as published in an external service level code list.

Data Type: ExternalServiceLevel1Code

Format: maxLength: 4  
minLength: 1

Usage EPC: Only 'SEPA' is allowed.

## 2.10 Proprietary

Message Element that is not part of the addendum for the IG SCT Netherlands but is available for FUTURE use in a SEPA AOS.

## 2.11 LocalInstrument

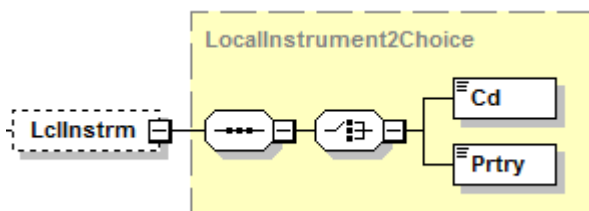

XML Tag: <LclInstrm>

Occurrence: [0..1]

Definition: User community specific instrument.

Usage ISO: This element is used to specify a local instrument, local clearing option and/or further qualify the service or service level.

Type: This message item is composed of one of the following LocalInstrument2Choice element(s):

Index	Or	MessageItem	<XMLTag>	Mult.	Represent./Type
2.12	{Or	Code	<Cd>	[1..1]	Code
2.13	Or}	Proprietary	<Prtry>	[1..1]	Text

Usage NL: Element may only be used in case of bilateral agreement

## 2.12 Code

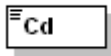

XML Tag: <Cd>

Occurrence: [1..1]

This message item is part of choice 2.11 LocalInstrument.

Definition: Specifies the local instrument, as published in an external local instrument code list.

Data Type: ExternalLocalInstrument1Code

Format: maxLength: 35  
minLength: 1

Usage NL: Element may only be used in case of bilateral agreement

## 2.13 Proprietary



XML Tag: <Prtry>

Occurrence: [1..1]

This message item is part of choice 2.11 LocalInstrument.

Definition: Specifies the local instrument, as a proprietary code.

Data Type: Max35Text

Format: maxLength: 35  
minLength: 1

Usage NL: Element may only be used in case of bilateral agreement

## 2.14 CategoryPurpose

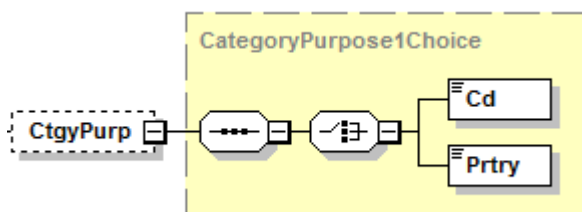

XML Tag: <CtgyPurp>

Occurrence: [0..1]

Definition: Specifies the high level purpose of the instruction based on a set of pre-defined categories.

Usage ISO: This is used by the initiating party to provide information concerning the processing of

the payment. It is likely to trigger special processing by any of the agents involved in the payment chain.

Type: This message item is composed of one of the following CategoryPurpose1Choice element(s):

Index	Or	MessageItem	<XMLTag>	Mult.	Represent./Type
2.15	{Or	Code	<Cd>	[1..1]	Code
2.16	Or}	Proprietary	<Prtry>	[1..1]	Text

Usage EPC: Depending on the agreement between the Originator and the Originator Bank, 'Category Purpose' may be forwarded to the Beneficiary Bank.

### 2.15 Code

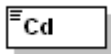

XML Tag: <Cd>

Occurrence: [1..1]

This message item is part of choice 2.14 CategoryPurpose.

Definition: Category purpose, as published in an external category purpose code list.

Data Type: ExternalCategoryPurpose1Code

Format: maxLength: 4  
minLength: 1

### 2.16 Proprietary

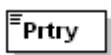

XML Tag: <Prtry>

Occurrence: [1..1]

This message item is part of choice 2.14 CategoryPurpose.

Definition: Category purpose, in a proprietary form.

Data Type: Max35Text

Format: maxLength: 35  
minLength: 1

## 2.17 RequestedExecutionDate

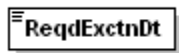

XML Tag: <ReqdExctnDt>

Occurrence: [1..1]

Definition: Date at which the initiating party requests the clearing agent to process the payment.

Usage ISO: This is the date on which the debtor's account is to be debited. If payment by cheque, the date when the cheque must be generated by the bank.

Data Type: Date

## 2.18 PoolingAdjustmentDate

Message Element that is not part of the addendum for the IG SCT Netherlands but is available for future use in a SEPA AOS.

## 2.19 Debtor

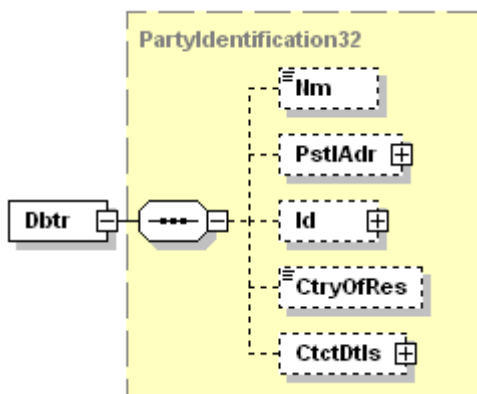

XML Tag: <Dbtr>

Occurrence: [1..1]

Definition: Party that owes an amount of money to the (ultimate) creditor.

Type: This message item is composed of the following PartyIdentification32 element(s):

MessageItem	<XMLTag>	Mult.	Represent./Type
Name	<Nm>	[0..1]	Text
PostalAddress	<PstlAdr>	[0..1]	
Identification	<Id>	[0..1]	
CountryOfResidence	<CtryOfRes>	[0..1]	Code
ContactDetails	<CtctDtIs>	[0..1]	



UsageEPC: 'Name' is Mandatory  
 'Name' is limited to 70 characters in length.  
 Only two occurrences of 'AddressLine' are allowed.  
 'OrganisationIdentification': Either 'BIC or BEI' or one occurrence of 'Other' is allowed.  
 'PrivateIdentification': Either 'Date and Place of Birth' or one occurrence of 'Other' is allowed.

## 2.20 DebtorAccount

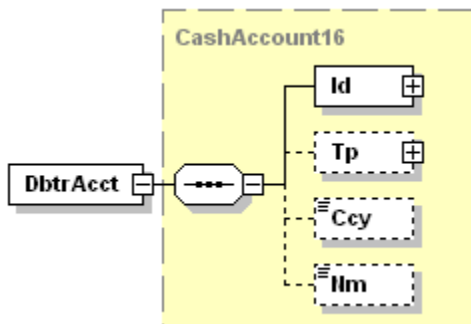

XML Tag: <DbtrAcct>

Occurrence: [1..1]

Definition: Unambiguous identification of the account of the debtor to which a debit entry will be made as a result of the transaction.

Type: This message item is composed of the following CashAccount16 element(s):

Or	MessageItem	<XMLTag>	Mult.	Represent./Type
	Identification	<Id>	[1..1]	
	Type	<Tp>	[0..1]	
	Currency	<Ccy>	[0..1]	Code
	Name	<Nm>	[0..1]	Text

UsageEPC: 'Identification': Only IBAN is allowed.

## 2.21 DebtorAgent

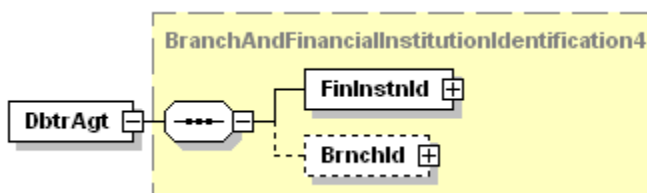

XML Tag: <DbtrAgt>

Occurrence: [1..1]

Definition: Financial institution servicing an account for the debtor.

Type: This message item is composed of the following  
BranchAndFinancialInstitutionIdentification4 element(s):

Or	MessageItem	<XMLTag>	Mult.	Represent./Type
	FinancialInstitutionIdentification	<FinInstnId>	[1..1]	
	BranchIdentification	<BrnchId>	[0..1]	

Usage EPC: Either BIC or 'Other/Identification' must be used. When 'Other/Identification' is used, only 'NOTPROVIDED' is allowed in 'Identification'. The BIC is mandatory for EU/EEA cross border transactions until 31 January 2016.

Usage NL: Advise EPC usage rules effective per 1 January 2013 for NL domestic payments.

## 2.22 DebtorAgentAccount

Message Element that is not part of the addendum for the IG SCT Netherlands but is available for future use in a SEPA AOS.

## 2.23 UltimateDebtor

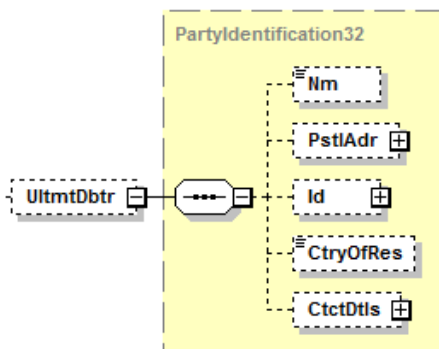

XML Tag: <UltmtDbtr>

Occurrence: [0..1]

Definition: Ultimate party that owes an amount of money to the (ultimate) creditor.

Usage ISO: UltimateDebtorRule

If 2.23 UltimateDebtor is present, then

2.70 CreditTransferTransactionInformation/UltimateDebtor is not allowed.

If 2.70 CreditTransferTransactionInformation/UltimateDebtor is present, then

2.23 UltimateDebtor is not allowed.

2.70 CreditTransferTransactionInformation/UltimateDebtor and 2.23 UltimateDebtor may both be absent.

Usage EPC: 'Name' is limited to 70 characters in length.  
 'OrganisationIdentification': Either 'BIC or BEI' or one occurrence of 'Other' is allowed.  
 'PrivateIdentification': Usage Rule: Either 'Date and Place of Birth' or one occurrence of 'Other' is allowed.

Type: This message item is composed of the following PartyIdentification32 element(s):

MessageItem	<XMLTag>	Mult.	Represent./Type
Name	<Nm>	[0..1]	Text
PostalAddress	<PstlAdr>	[0..1]	
Identification	<Id>	[0..1]	
CountryOfResidence	<CtryOfRes>	[0..1]	Code
ContactDetails	<CtctDtls>	[0..1]	

Guideline(s): UltimateDebtorGuideline  
 UltimateDebtor may only be present if different from Debtor.

## 2.24 ChargeBearer

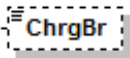

XML Tag: <ChrgBr>  
 Occurrence: [0..1]  
 Definition: Specifies which party/parties will bear the charges associated with the processing of the payment transaction.  
 Data Type: Code

Code	Name	Definition
SLEV	FollowingServiceLevel	Charges are to be applied following the rules agreed in the service level and/or scheme.

### Usage ISO: ChargeBearerRule

If 2.24 ChargeBearer is present, then 2.51 CreditTransferTransactionInformation/ChargeBearer is not allowed. If 2.51 CreditTransferTransactionInformation/ChargeBearer is present, then 2.24 ChargeBearer is not allowed. Additionally, 2.51 CreditTransferTransactionInformation/ChargeBearer and 2.24 ChargeBearer may both be absent.

Usage EPC: Only 'SLEV' is allowed. It is recommended that this element be specified at 'Payment Information' level'.

### **2.25 ChargesAccount**

Message Element that is not part of the addendum for the IG SCT Netherlands but is available for future use in a SEPA AOS.

### **2.26 ChargesAccountAgent**

Message Element that is not part of the addendum for the IG SCT Netherlands but is available for future use in a SEPA AOS.

## 2.27 CreditTransferTransactionInformation

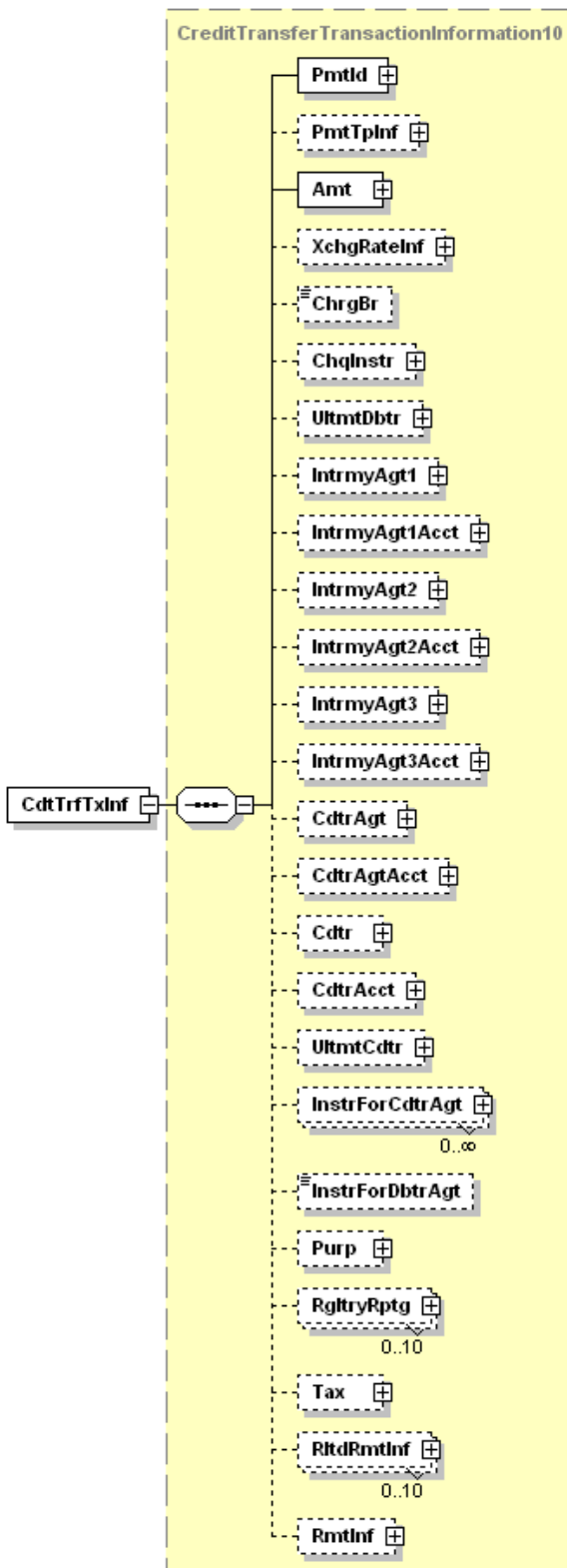

XML Tag: <CdtTrfTxInf>

Occurrence: [1..n]

Definition: Set of elements used to provide information on the individual transaction(s) included in the message.

Type: This message item is composed of the following  
CreditTransferTransactionInformation10 element(s):

Index	Or	MessageItem	<XMLTag>	Mult.	Represent./Type
2.28		PaymentIdentification	<PmtId>	[1..1]	
2.31		PaymentTypeInfoInformation	<PmtTpInf>	[0..1]	
2.42		Amount	<Amt>	[1..1]	
2.47		ExchangeRateInformation	<XchgRateInf>	[0..1]	
2.51		ChargeBearer	<ChrgBr>	[0..1]	Code
2.52		ChequeInstruction	<ChqInstr>	[0..1]	
2.70		UltimateDebtor	<UltmtDbtr>	[0..1]	+
2.71		IntermediaryAgent1	<IntrmyAgt1>	[0..1]	+
2.72		IntermediaryAgent1Account	<IntrmyAgt1Acct>	[0..1]	+
2.73		IntermediaryAgent2	<IntrmyAgt2>	[0..1]	+
2.74		IntermediaryAgent2Account	<IntrmyAgt2Acct>	[0..1]	+
2.75		IntermediaryAgent3	<IntrmyAgt3>	[0..1]	+
2.76		IntermediaryAgent3Account	<IntrmyAgt3Acct>	[0..1]	+
2.77		CreditorAgent	<CdtrAgt>	[0..1]	+
2.78		CreditorAgentAccount	<CdtrAgtAcct>	[0..1]	+
2.79		Creditor	<Cdtr>	[0..1]	+
2.80		CreditorAccount	<CdtrAcct>	[0..1]	+
2.81		UltimateCreditor	<UltmtCdtr>	[0..1]	+
2.82		InstructionForCreditorAgent	<InstrForCdtrAgt>	[0..n]	
2.85		InstructionForDebtorAgent	<InstrForDbtrAgt>	[0..1]	Text
2.86		Purpose	<Purp>	[0..1]	
2.89		RegulatoryReporting	<RgltryRptg>	[0..10]	+
2.90		Tax	<Tax>	[0..1]	+
2.91		RelatedRemittanceInformation	<RltdRmtInf>	[0..10]	
2.98		RemittanceInformation	<RmtInf>	[0..1]	

## 2.28 PaymentIdentification

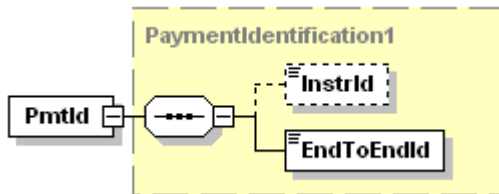

XML Tag: <PmtId>

Occurrence: [1..1]

Definition: Set of elements used to reference a payment instruction.

Type: This message item is composed of the following PaymentIdentification1 element(s):

Index	Or	MessageItem	<XMLTag>	Mult.	Represent./Type
2.29		InstructionIdentification	<InstrId>	[0..1]	Text
2.30		EndToEndIdentification	<EndToEndId>	[1..1]	Text

## 2.29 InstructionIdentification



XML Tag: <InstrId>

Occurrence: [0..1]

Definition: Unique identification as assigned by an instructing party for an instructed party to unambiguously identify the instruction.

Usage ISO: the instruction identification is a point to point reference that can be used between the instructing party and the instructed party to refer to the individual instruction. It can be included in several messages related to the instruction.

Data Type: Max35Text

Format: maxLength: 35  
minLength: 1

## 2.30 EndToEndIdentification

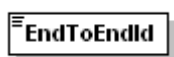

XML Tag: <EndToEndId>

Occurrence: [1..1]

Definition: Unique identification assigned by the initiating party to unambiguously identify the transaction. This identification is passed on, unchanged, throughout the entire end-to-

end chain.

Usage ISO: The end-to-end identification can be used for reconciliation or to link tasks relating to the transaction. It can be included in several messages related to the transaction.

Data Type: Max35Text

Format: maxLength: 35  
minLength: 1

Usage EPC: Originator's Reference to the Credit Transfer

### 2.31 PaymentTypeInformation

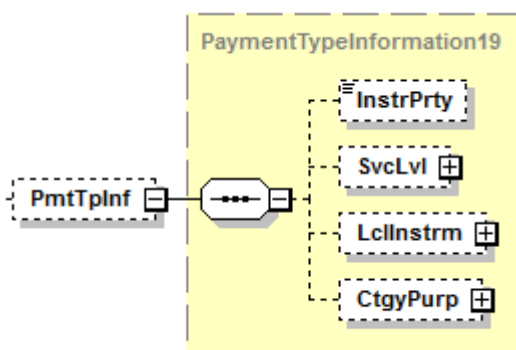

XML Tag: <PmtTplnf>

Occurrence: [0..1]

Definition: Set of elements used to further specify the type of transaction.

Type: This message item is composed of the following PaymentTypeInformation19 element(s):

Index	Or	MessageItem	<XMLTag>	Mult.	Represent./Type
2.32		InstructionPriority	<InstrPrty>	[0..1]	Code
2.33		ServiceLevel	<SvcLvl>	[0..1]	
2.36		LocalInstrument	<LclInstrm>	[0..1]	
2.39		CategoryPurpose	<CtgyPurp>	[0..1]	

Usage EPC: If used, it is recommended to be used at 'Payment Information' level and not at 'Credit Transfer Transaction Information' level.

### 2.32 InstructionPriority

Message Element that is not part of the addendum for the IG SCT Netherlands but is available for future use in a SEPA AOS.



### 2.33 ServiceLevel

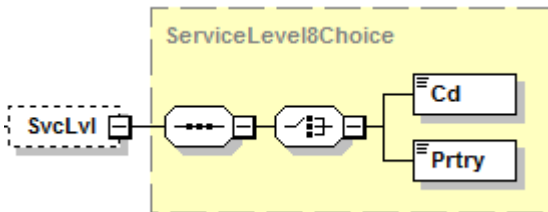

XML Tag: <SvcLvl>  
 Occurrence: [0..1]  
 Definition: Agreement under which or rules under which the transaction should be processed.  
 Type: This message item is composed of one of the following ServiceLevel8Choice element(s):

Index	Or	MessageItem	<XMLTag>	Mult.	Represent./Type
2.34	{Or	Code	<Cd>	[1..1]	Code
2.35	Or}	Proprietary	<Prtry>	[1..1]	Text

Usage EPC: Usage is recommended.

### 2.34 Code

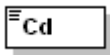

XML Tag: <Cd>  
 Occurrence: [1..1]  
 This message item is part of choice 2.33 ServiceLevel.  
 Definition: Specifies a pre-agreed service or level of service between the parties, as published in an external service level code list.  
 Data Type: ExternalServiceLevel1Code  
 Format: maxLength: 4  
 minLength: 1  
 Usage EPC: Only 'SEPA' is allowed.

### 2.35 Proprietary

Message Element that is not part of the addendum for the IG SCT Netherlands but is available for future use in a SEPA AOS.

## 2.36 LocalInstrument

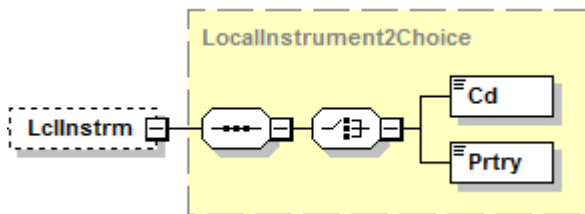

XML Tag: <LclInstrm>

Occurrence: [0..1]

Definition: User community specific instrument.

Usage ISO: This element is used to specify a local instrument, local clearing option and/or further qualify the service or service level.

Type: This message item is composed of one of the following LocalInstrument2Choice element(s):

Index	Or	MessageItem	<XMLTag>	Mult.	Represent./Type
2.37	{Or	Code	<Cd>	[1..1]	Code
2.38	Or}	Proprietary	<Prtry>	[1..1]	Text

## 2.37 Code

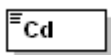

XML Tag: <Cd>

Occurrence: [1..1]

This message item is part of choice 2.36 LocalInstrument.

Definition: Specifies the local instrument, as published in an external local instrument code list see Annex D Overview ISO codes.

Data Type: ExternalLocalInstrument1Code

Format: maxLength: 35  
minLength: 1

## 2.38 Proprietary

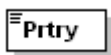

XML Tag: <Prtry>

Occurrence: [1..1]

This message item is part of choice 2.36 LocalInstrument.

Definition: Specifies the local instrument, as a proprietary code.

Data Type: Max35Text

Format: maxLength: 35  
minLength: 1

### 2.39 CategoryPurpose

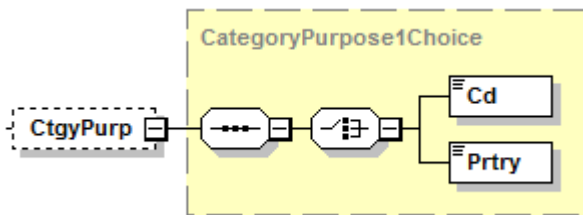

XML Tag: <CtgyPurp>

Occurrence: [0..1]

Definition: Specifies the high level purpose of the instruction based on a set of pre-defined categories.

Usage ISO: This is used by the initiating party to provide information concerning the processing of the payment. It is likely to trigger special processing by any of the agents involved in the payment chain.

Type: This message item is composed of one of the following CategoryPurpose1Choice element(s):

Index	Or	MessageItem	<XMLTag>	Mult.	Represent./Type
2.40	{Or	Code	<Cd>	[1..1]	Code
2.41	Or}	Proprietary	<Prtry>	[1..1]	Text

Usage EPC: Depending on the agreement between the Originator and the Originator Bank, 'Category Purpose' may be forwarded to the Beneficiary Bank

### 2.40 Code

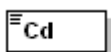

XML Tag: <Cd>

Occurrence: [1..1]

This message item is part of choice 2.39 CategoryPurpose.

Definition: Category purpose, as published in an external category purpose code list.

Data Type: ExternalCategoryPurpose1Code

Format: maxLength: 4

minLength: 1

## 2.41 Proprietary



XML Tag: <Prtry>

Occurrence: [1..1]

This message item is part of choice 2.39 CategoryPurpose.

Definition: Category purpose, in a proprietary form.

Data Type: Max35Text

Format: maxLength: 35

minLength: 1

## 2.42 Amount

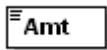

XML Tag: <Amt>

Occurrence: [1..1]

Definition: Amount of money to be moved between the debtor and creditor, before deduction of charges, expressed in the currency as ordered by the initiating party.

Type: This message item is composed of one of the following AmountType3Choice element(s):

Index	Or	MessageItem	<XMLTag>	Mult.	Represent./Type
2.43	{Or	InstructedAmount	<InstdAmt>	[1..1]	Amount
2.44	Or}	EquivalentAmount	<EqvtAmt>	[1..1]	

## 2.43 InstructedAmount

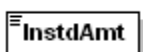

XML Tag: <InstdAmt>

Occurrence: [1..1]

This message item is part of choice 2.42 Amount.

**Definition:** Amount of money to be moved between the debtor and creditor, before deduction of charges, expressed in the currency as ordered by the initiating party.

**Data Type:** *ActiveOrHistoricCurrencyAndAmount*

This data type must be used with the following XML Attribute: Currency (Ccy) which is typed by:

*ActiveOrHistoricCurrencyCode*.

**Format:** *ActiveOrHistoricCurrencyAndAmount*

fractionDigits: 5

minInclusive: 0

totalDigits: 18

*ActiveOrHistoricCurrencyCode*

[A-Z]{3,3}

**Usage ISO:** *ActiveOrHistoricCurrencyAndAmount*

CurrencyAmount

The number of fractional digits (or minor unit of currency) must comply with ISO 4217.

Note: The decimal separator is a dot.

*ActiveOrHistoricCurrencyCode*

*ActiveOrHistoricCurrency*

The Currency Code must be registered, or have already been registered. Valid active or historic currency codes are registered with the ISO 4217 Maintenance Agency, consist of three (3) contiguous letters, and may be or not be withdrawn on the day the message containing the Currency is exchanged.

**Usage EPC:** Only 'EUR' is allowed.

Amount must be 0.01 or more and 999999999.99 or less.

The fractional part has a maximum of two digits.

## 2.44 EquivalentAmount

Message Element that is not part of the addendum for the IG SCT Netherlands but is available for future use in a SEPA AOS.

## 2.45 Amount

Message Element that is not to be used in SEPA Payments for NL.

## 2.46 CurrencyOfTransfer

Message Element that is not to be used in SEPA Payments for NL.

## 2.47 ExchangeRateInformation

Message Element that is not part of the addendum for the IG SCT Netherlands but is available for future use in a SEPA AOS.

## 2.48 ExchangeRate

Message Element that is not to be used in SEPA Payments for NL.

## 2.49 RateType

Message Element that is not to be used in SEPA Payments for NL.

## 2.50 ContractIdentification

Message Element that is not to be used in SEPA Payments for NL.

## 2.51 ChargeBearer

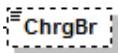

XML Tag: <ChrgBr>

Occurrence: [0..1]

Definition: Specifies which party/parties will bear the charges associated with the processing of the payment transaction.

Data Type: Code

Usage ISO: ChargeBearerRule

If 2.24 ChargeBearer is present, then 2.51 CreditTransferTransactionInformation/ChargeBearer is not allowed. If 2.51 CreditTransferTransactionInformation/ChargeBearer is present, then 2.24 ChargeBearer is not allowed. Additionally, 2.51 CreditTransferTransactionInformation/ChargeBearer and 2.24 ChargeBearer may both be absent.

Usage EPC: Only 'SLEV' is allowed.

It is recommended that this element is specified at 'Payment Information' level.

Code	Name	Definition
SLEV	FollowingServiceLevel	FollowingServiceLevel Charges are to be applied following

---

		the rules agreed in the service level and/or scheme.
--	--	--

### **2.52 ChequeInstruction**

Message Element that is not part of the addendum for the IG SCT Netherlands but is available for future use in a SEPA AOS.

### **2.53 ChequeType**

Message Element that is not to be used in SEPA Payments for NL.

### **2.54 ChequeNumber**

Message Element that is not to be used in SEPA Payments for NL.

### **2.55 ChequeFrom**

Message Element that is not to be used in SEPA Payments for NL.

### **2.56 Name**

Message Element that is not to be used in SEPA Payments for NL.

### **2.57 Address**

Message Element that is not to be used in SEPA Payments for NL.

### **2.58 DeliveryMethod**

Message Element that is not to be used in SEPA Payments for NL.

### **2.59 Code**

Message Element that is not to be used in SEPA Payments for NL.

### **2.60 Proprietary**

Message Element that is not to be used in SEPA Payments for NL.

### **2.61 DeliverTo**

Message Element that is not to be used in SEPA Payments for NL.

### **2.62 Name**

Message Element that is not to be used in SEPA Payments for NL.

### 2.63 Address

Message Element that is not to be used in SEPA Payments for NL.

### 2.64 InstructionPriority

Message Element that is not to be used in SEPA Payments for NL.

### 2.65 ChequeMaturityDate

Message Element that is not to be used in SEPA Payments for NL.

### 2.66 FormsCode

Message Element that is not to be used in SEPA Payments for NL.

### 2.67 MemoField

Message Element that is not to be used in SEPA Payments for NL.

### 2.68 RegionalClearingZone

Message Element that is not to be used in SEPA Payments for NL.

### 2.69 PrintLocation

Message Element that is not to be used in SEPA Payments for NL.

### 2.70 UltimateDebtor

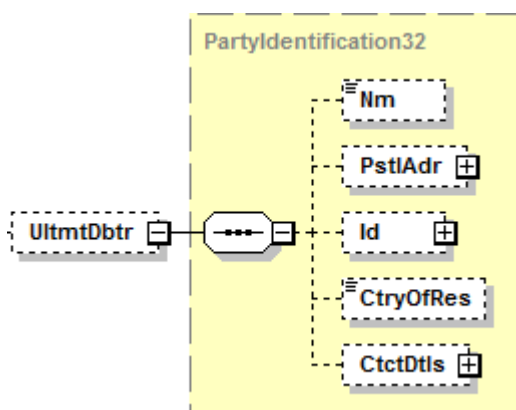

XML Tag: <UltmtDbtr>

Occurrence: [0..1]

Definition: Ultimate party that owes an amount of money to the (ultimate) creditor.

Type: This message item is composed of the following PartyIdentification32 element(s):



MessageItem	<XMLTag>	Mult.	Represent./Type
Name	<Nm>	[0..1]	Text
PostalAddress	<PstlAdr>	[0..1]	
Identification	<Id>	[0..1]	
CountryOfResidence	<CtryOfRes>	[0..1]	Code
ContactDetails	<CtctDtls>	[0..1]	

Usage ISO: UltimateDebtorRule

If 2.23 UltimateDebtor is present, then

2.70 CreditTransferTransactionInformation/UltimateDebtor is not allowed.

If 2.70 CreditTransferTransactionInformation/UltimateDebtor is present, then

2.23 UltimateDebtor is not allowed.

2.70 CreditTransferTransactionInformation/UltimateDebtor and 2.23 UltimateDebtor may both be absent.

Usage EPC: 'Name' is limited to 70 characters in length.

'OrganisationIdentification': Either 'BIC or BEI' or one occurrence of 'Other' is allowed.

'PrivateIdentification': Either 'Date and Place of Birth' or one occurrence of 'Other' is allowed.

### 2.71 IntermediaryAgent1

Message Element that is not part of the addendum for the IG SCT Netherlands but is available for future use in a SEPA AOS.

### 2.72 IntermediaryAgent1Account

Message Element that is not part of the addendum for the IG SCT Netherlands but is available for future use in a SEPA AOS.

### 2.73 IntermediaryAgent2

Message Element that is not part of the addendum for the IG SCT Netherlands but is available for future use in a SEPA AOS.

### 2.74 IntermediaryAgent2Account

Message Element that is not part of the addendum for the IG SCT Netherlands but is available for future use in a SEPA AOS.

### 2.75 IntermediaryAgent3

Message Element that is not part of the addendum for the IG SCT Netherlands but is available for future use in a SEPA AOS.

### 2.76 IntermediaryAgent3Account

Message Element that is not part of the addendum for the IG SCT Netherlands but is available for future use in a SEPA AOS.

### 2.77 CreditorAgent

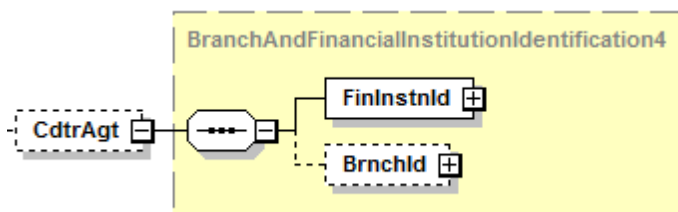

XML Tag: <CdtrAgt>

Occurrence: [0..1]

Definition: Financial institution servicing an account for the creditor.

Type: This message item is composed of the following  
BranchAndFinancialInstitutionIdentification4 element(s):

MessageItem	<XMLTag>	Mult.	Represent./Type
FinancialInstitutionIdentification	<FinInstnId>	[1..1]	
BranchIdentification	<BrnchId>	[0..1]	

For additional Type information, please refer to BranchAndFinancialInstitutionIdentification4 in Annex E Generic ISO message Items.

Usage EPC: Only BIC is allowed.

## 2.78 CreditorAgentAccount

Message Element that is not part of the addendum for the IG SCT Netherlands but is available for future use in a SEPA AOS.

## 2.79 Creditor

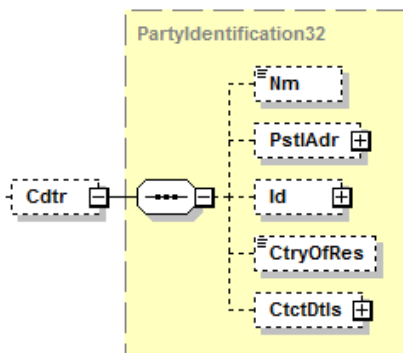

XML Tag: <Cdtr>

Occurrence: [0..1]

Definition: Party to which an amount of money is due.

Type: This message item is composed of the following PartyIdentification32 element(s):

MessageItem	<XMLTag>	Mult.	Represent./Type
Name	<Nm>	[0..1]	Text
PostalAddress	<PstlAdr>	[0..1]	
Identification	<Id>	[0..1]	
CountryOfResidence	<CtryOfRes>	[0..1]	Code
ContactDetails	<CtctDtls>	[0..1]	

For additional Type information, please refer to PartyIdentification32 in

Annex E Generic ISO message Items.

Usage EPC: 'Creditor' is Mandatory

'Name' is Mandatory

'Name' is limited to 70 characters in length.

Only two occurrences are allowed of 'AddressLine'.

'OrganisationIdentification': Either 'BIC or BEI' or one occurrence of 'Other' is allowed.

'PrivateIdentification': Either 'Date and Place of Birth' or one occurrence of 'Other' is allowed.

## 2.80 CreditorAccount

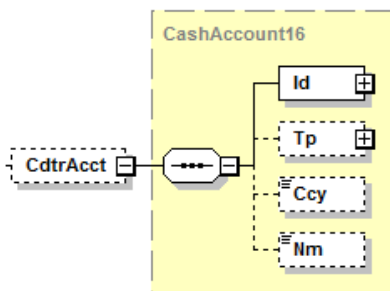

XML Tag: <CdtrAcct>

Occurrence: [0..1]

Definition: Unambiguous identification of the account of the creditor to which a credit entry will be posted as a result of the payment transaction.

Type: This message item is composed of the following CashAccount16 element(s):

MessageItem	<XMLTag>	Mult.	Represent./Type
Identification	<Id>	[1..1]	
Type	<Tp>	[0..1]	
Currency	<Ccy>	[0..1]	Code
Name	<Nm>	[0..1]	Text

For additional Type information, please refer to **CashAccount16** in

Annex E Generic ISO message Items.

Usage EPC: 'CreditorAccount' is Mandatory

Only IBAN is allowed.

## 2.81 UltimateCreditor

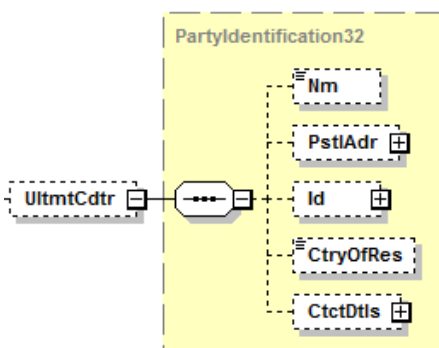

XML Tag: <UltmtCdtr>

Occurrence: [0..1]

Definition: Ultimate party to which an amount of money is due.

Type: This message item is composed of the following PartyIdentification32 element(s):

MessageItem	<XMLTag>	Mult.	Represent./Type
Name	<Nm>	[0..1]	Text
PostalAddress	<PstlAdr>	[0..1]	
Identification	<Id>	[0..1]	
CountryOfResidence	<CtryOfRes>	[0..1]	Code
ContactDetails	<CtctDtls>	[0..1]	

Usage EPC: 'Name' is limited to 70 characters in length.

'OrganisationIdentification': Either 'BIC or BEI' or one occurrence of 'Other' is allowed.

'PrivateIdentification': Either 'Date and Place of Birth' or one occurrence of 'Other' is allowed.

## 2.82 InstructionForCreditorAgent

Message Element that is not part of the addendum for the IG SCT Netherlands but is available for future use in a SEPA AOS.

## 2.83 Code

Message Element that is not to be used in SEPA Payments for NL.

## 2.84 InstructionInformation

Message Element that is not to be used in SEPA Payments for NL.

## 2.85 InstructionForDebtorAgent

Message Element that is not part of the addendum for the IG SCT Netherlands but is available for future use in a SEPA AOS.

## 2.86 Purpose

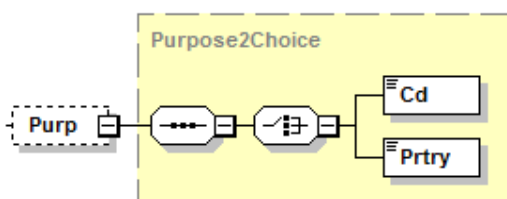

XML Tag: <Purp>

Occurrence: [0..1]

**Definition:** Underlying reason for the payment transaction.  
**Usage ISO:** Purpose is used by the end-customers, that is initiating party, (ultimate) debtor, (ultimate) creditor to provide information concerning the nature of the payment. Purpose is a content element, which is not used for processing by any of the agents involved in the payment chain.  
**Type:** This message item is composed of one of the following Purpose2Choice element(s):

Index	Or	MessageItem	<XMLTag>	Mult.	Represent./Type
2.87	{Or	Code	<Cd>	[1..1]	Code
2.88	Or}	Proprietary	<Prtry>	[1..1]	Text

### 2.87 Code

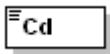

**XML Tag:** <Cd>

**Occurrence:** [1..1]

This message item is part of choice 2.86 Purpose.

**Definition:** Underlying reason for the payment transaction, as published in an external purpose code list.

**Data Type:** ExternalPurpose1Code

**Format:** maxLength: 4  
minLength: 1

### 2.88 Proprietary

Message Element that is not part of the addendum for the IG SCT Netherlands but is available for future use in a SEPA AOS.

### 2.89 RegulatoryReporting

Message Element that is not part of the addendum for the IG SCT Netherlands but is available for future use in a SEPA AOS.

### 2.90 Tax

Message Element that is not part of the addendum for the IG SCT Netherlands but is available for future use in a SEPA AOS.

## 2.91 RelatedRemittanceInformation

Message Element that is not part of the addendum for the IG SCT Netherlands but is available for future use in a SEPA AOS.

## 2.92 RemittanceIdentification

Message Element that is not to be used in SEPA Payments for NL.

## 2.93 RemittanceLocationMethod

Message Element that is not to be used in SEPA Payments for NL.

## 2.94 RemittanceLocationElectronicAddress

Message Element that is not to be used in SEPA Payments for NL.

## 2.95 RemittanceLocationPostalAddress

Message Element that is not to be used in SEPA Payments for NL.

## 2.96 Name

Message Element that is not to be used in SEPA Payments for NL.

## 2.97 Address

Message Element that is not to be used in SEPA Payments for NL.

## 2.98 RemittanceInformation

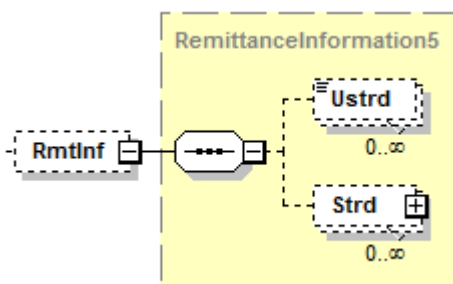

XML Tag: <RmtInf>

Occurrence: [0..1]

Definition: Information supplied to enable the matching of an entry with the items that the transfer is intended to settle, such as commercial invoices in an accounts' receivable system.

Type: This message item is composed of the following RemittanceInformation5 element(s):

Index	Or	MessageItem	<XMLTag>	Mult.	Represent./Type
2.99		Unstructured	<Ustrd>	[0..n]	Text
2.100		Structured	<Strd>	[0..n]	

Usage EPC: Either 'Structured' or 'Unstructured' may be present.

## 2.99 Unstructured

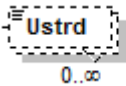

XML Tag: <Ustrd>

Occurrence: [0..n]

Definition: Information supplied to enable the matching/reconciliation of an entry with the items that the payment is intended to settle, such as commercial invoices in an accounts' receivable system, in an unstructured form.

Data Type: Max140Text

Format: maxLength: 140

minLength: 1

Usage EPC: 'Unstructured' may carry structured remittance information, as agreed between the Originator and the Beneficiary.

Format Rule: Only one occurrence of 'Unstructured' is allowed.

## 2.100 Structured

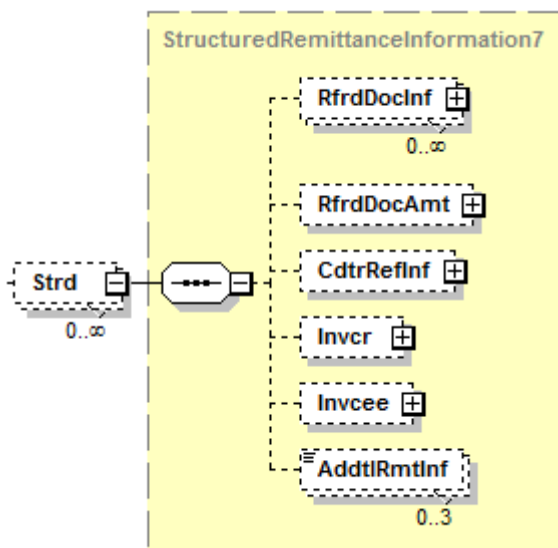

XML Tag: <Strd>



Occurrence: [0..n]

Definition: Information supplied to enable the matching/reconciliation of an entry with the items that the payment is intended to settle, such as commercial invoices in an accounts' receivable system, in a structured form.

Type: This message item is composed of the following StructuredRemittanceInformation7 element(s):

Index	Or	MessageItem	<XMLTag>	Mult.	Represent./Type
2.101		ReferredDocumentInformation	<RfrdDocInf>	[0..n]	
2.109		ReferredDocumentAmount	<RfrdDocAmt>	[0..1]	
2.120		CreditorReferenceInformation	<CdtrRefInf>	[0..1]	
2.127		Invoicer	<Invcr>	[0..1]	+
2.128		Invoicee	<Invcee>	[0..1]	+
2.129		AdditionalRemittanceInformation	<AddtlRmtInf>	[0..3]	Text

Usage EPC: Format Rule: 'Structured' can be used, provided the tags and the data within the 'Structured' element do not exceed 140 characters in length.

Format Rule: Only one occurrence of 'Structured' is allowed.

### 2.101 ReferredDocumentInformation

Message Element that is not part of the addendum for the IG SCT Netherlands but is available for future use in a SEPA AOS.

### 2.102 Type

Message Element that is not to be used in SEPA Payments for NL.

### 2.103 CodeOrProprietary

Message Element that is not to be used in SEPA Payments for NL.

### 2.104 Code

Message Element that is not to be used in SEPA Payments for NL.

### 2.105 Proprietary

Message Element that is not to be used in SEPA Payments for NL.

### 2.106 Issuer

Message Element that is not to be used in SEPA Payments for NL.

**2.107 Number**

Message Element that is not to be used in SEPA Payments for NL.

**2.108 RelatedDate**

Message Element that is not to be used in SEPA Payments for NL.

**2.109 ReferredDocumentAmount**

Message Element that is not part of the addendum for the IG SCT Netherlands but is available for future use in a SEPA AOS.

**2.110 DuePayableAmount**

Message Element that is not to be used in SEPA Payments for NL.

**2.111 DiscountAppliedAmount**

Message Element that is not to be used in SEPA Payments for NL.

**2.112 CreditNoteAmount**

Message Element that is not to be used in SEPA Payments for NL.

**2.113 TaxAmount**

Message Element that is not to be used in SEPA Payments for NL.

**2.114 AdjustmentAmountAndReason**

Message Element that is not to be used in SEPA Payments for NL.

**2.115 Amount**

Message Element that is not to be used in SEPA Payments for NL.

**2.116 CreditDebitIndicator**

Message Element that is not to be used in SEPA Payments for NL.

**2.117 Reason**

Message Element that is not to be used in SEPA Payments for NL.

**2.118 AdditionalInformation**

Message Element that is not to be used in SEPA Payments for NL.

### 2.119 RemittedAmount

Message Element that is not to be used in SEPA Payments for NL.

### 2.120 CreditorReferenceInformation

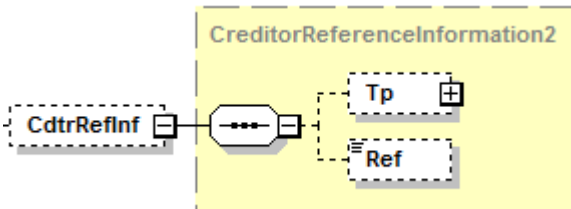

XML Tag: <CdtrRefInf>

Occurrence: [0..1]

Definition: Reference information provided by the creditor to allow the identification of the underlying documents.

Type: This message item is composed of the following CreditorReferenceInformation2 element(s):

Index	Or	MessageItem	<XMLTag>	Mult.	Represent./Type
2.121		Type	<Tp>	[0..1]	
2.126		Reference	<Ref>	[0..1]	Text

Usage EPC: When present, the Debtor Bank is not obliged to validate the reference information. When used both, Creditor Reference Type and Creditor Reference must be present.

### 2.121 Type

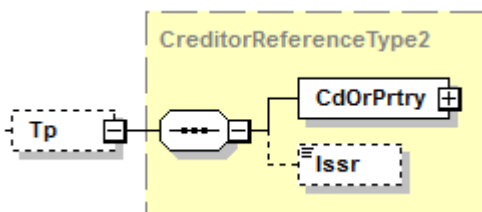

XML Tag: <Tp>

Occurrence: [0..1]

Definition: Specifies the type of creditor reference.

Type: This message item is composed of the following CreditorReferenceType2 element(s):

Index	Or	MessageItem	<XMLTag>	Mult.	Represent./Type
2.122		CodeOrProprietary	<CdOrPrtry>	[1..1]	
2.125		Issuer	<Issr>	[0..1]	Text

## 2.122 CodeOrProprietary

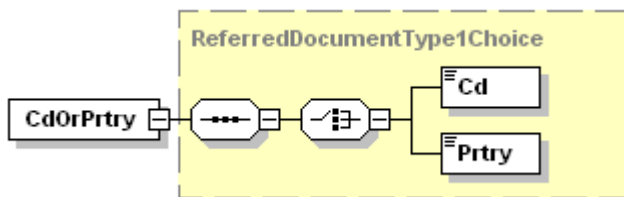

XML Tag: <CdOrPrtry>

Occurrence: [1..1]

Definition: Coded or proprietary format creditor reference type.

Type: This message item is composed of one of the following CreditorReferenceType1Choice element(s):

Index	Or	MessageItem	<XMLTag>	Mult.	Represent./Type
2.123	{Or	Code	<Cd>	[1..1]	Code
2.124	Or}	Proprietary	<Prtry>	[1..1]	Text

## 2.123 Code

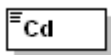

XML Tag: <Cd>

Occurrence: [1..1]

This message item is part of choice 2.122 CodeOrProprietary.

Definition: Type of creditor reference, in a coded form.

Data Type: Code

Usage EPC: Only 'SCOR' is allowed.

Code	Name	Definition
SCOR	StructuredCommunicationReference	Document is a structured communication reference provided by the creditor to identify the referred transaction.

### 2.124 Proprietary

Message Element that is not part of the addendum for the IG SCT Netherlands but is available for future use in a SEPA AOS.

### 2.125 Issuer

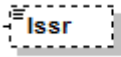

XML Tag:	<Issr>
Occurrence:	[0..1]
Definition:	Entity that assigns the credit reference type.
Data Type:	Max35Text
Format:	maxLength: 35 minLength: 1
Usage NL:	If the Dutch Structured Communication is used the following value must be used as Issuer "CUR".

### 2.126 Reference

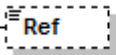

XML Tag:	<Ref>
Occurrence:	[0..1]
Definition:	Unique reference, as assigned by the creditor, to unambiguously refer to the payment transaction.
Data Type:	Max35Text
Format:	maxLength: 35 minLength: 1
Usage ISO:	If available, the initiating party should provide this reference in the structured remittance information, to enable reconciliation by the creditor upon receipt of the amount of money. If the business context requires the use of a creditor reference or a payment remit identification, and only one identifier can be passed through the end-to-end chain, the creditor's reference or payment remittance identification should be quoted in the end-to-end transaction identification.

- Usage EPC: If a Creditor Reference contains a check digit, the receiving bank is not required to validate this.  
If the receiving bank validates the check digit and if this validation fails, the bank may continue its processing and send the transaction to the next party in the chain  
RF Creditor Reference may be used (ISO 11649)
- Usage NL: If the Dutch Structured Communication is used (indicated through the issuer value "CUR") the reference must be compliant with the rules for the structured Communication ("Betalingsskenmerk").

### **2.127 Invoicer**

Message Element that is not part of the addendum for the IG SCT Netherlands but is available for future use in a SEPA AOS.

### **2.128 Invoicee**

Message Element that is not part of the addendum for the IG SCT Netherlands but is available for future use in a SEPA AOS.

### **2.129 AdditionalRemittanceInformation**

Message Element that is not part of the addendum for the IG SCT Netherlands but is available for future use in a SEPA AOS.

## Annex A Detailed message item overview

The following table provides a summary of the message items to be used for a SEPA Credit Transfer. A more detailed description of each message item is given in the Message items description.

Only the message items that are in scope for this IG are presented.

<i>Index</i>	<i>Generic ISO Index</i>	<i>Or</i>	<i>Message Item</i>	<i>&lt;XML Tag&gt;</i>	<i>Mult.</i>	<i>Type</i>
0.0			+Message root	<CstmrCdtTrfInItN>	[1..1]	
1.0			+GroupHeader	<GrpHdr>	[1..1]	
1.1			++ MessageIdentification	<MsgId>	[1..1]	Text
1.2			++ CreationDateTime	<CreDtTm>	[1..1]	DateTime
1.6			++ NumberOfTransactions	<NbOfTxs>	[1..1]	Text
1.7			+ +ControlSum	<CtrlSum>	[0..1]	Quantity
1.8			+ + + InitiatingParty	<InitgPty>	[1..1]	+
1.8	9.1.0		+ + + + Name	<Nm>	[0..1]	Text
1.8	9.1.12		+ + + + Identification	<Id>	[0..1]	
1.8	9.1.13	{Or	+ + + + + OrganisationIdentification	<OrgId>	[1..1]	
1.8	9.1.14		+ + + + + BICOrBEI	<BICOrBEI>	[0..1]	Identifier
1.8	9.1.15		+ + + + + Other	<Othr>	[0..n]	
1.8	9.1.16		+ + + + + + Identification	<Id>	[1..1]	Text
1.8	9.1.17		+ + + + + + SchemeName	<SchmeNm>	[0..1]	
1.8	9.1.18	{{Or	+ + + + + + + Code	<Cd>	[1..1]	Code
1.8	9.1.19	Or}}	+ + + + + + + Proprietary	<Prtry>	[1..1]	Text
1.8	9.1.20		+ + + + + + + Issuer	<Issr>	[0..1]	Text
1.8	9.1.21	Or}	+ + + + + PrivateIdentification	<PrvtId>	[1..1]	
1.8	9.1.22		+ + + + + + DateAndPlaceOfBirth	<DtAndPlcOfBirth>	[0..1]	
1.8	9.1.23		+ + + + + + + BirthDate	<BirthDt>	[1..1]	Date
1.8	9.1.24		+ + + + + + + ProvinceOfBirth	<PrvcOfBirth>	[0..1]	Text
1.8	9.1.25		+ + + + + + + CityOfBirth	<CityOfBirth>	[1..1]	Text
1.8	9.1.26		+ + + + + + + CountryOfBirth	<CtryOfBirth>	[1..1]	Code
1.8	9.1.27		+ + + + + + Other	<Othr>	[0..n]	
1.8	9.1.28		+ + + + + + + Identification	<Id>	[1..1]	Text

<b>Index</b>	<b>Generic ISO Index</b>	<b>Or</b>	<b>Message Item</b>	<b>&lt;XML Tag&gt;</b>	<b>Mult.</b>	<b>Type</b>
1.8	9.1.29		+++++ SchemeName	<SchmeNm>	[0..1]	
1.8	9.1.30	{Or	+++++ Code	<Cd>	[1..1]	Code
1.8	9.1.31	Or}}	+++++ Proprietary	<Prtry>	[1..1]	Text
1.8	9.1.32		+++++ Issuer	<lssr>	[0..1]	Text
2.0			+ PaymentInformation	<PmtInf>	[1..n]	
2.1			+ + PaymentInformationIdentification	<PmtInfId>	[1..1]	Text
2.2			+ + PaymentMethod	<PmtMtd>	[1..1]	Code
2.3			+ + BatchBooking	<BtchBookg>	[0..1]	Indicator
2.4			+ + NumberOfTransactions	<NbOfTxS>	[0..1]	Text
2.5			+ + ControlSum	<CtrlSum>	[0..1]	Quantity
2.6			+ + PaymentTypeInformation	<PmtTplnf>	[0..1]	
2.7			+ + + InstructionPriority	<InstrPrty>	[0..1]	Code
2.8			+ + + ServiceLevel	<SvcLvl>	[0..1]	
2.9		{Or	+ + + + Code	<Cd>	[1..1]	Code
2.11			+ + + LocalInstrument	<LclInstrm>	[0..1]	
2.12		{Or	+ + + + Code	<Cd>	[1..1]	Code
2.13		Or}	+ + + + Proprietary	<Prtry>	[1..1]	Text
2.14			+ + + CategoryPurpose	<CtgyPurp>	[0..1]	
2.15		{Or	+ + + + Code	<Cd>	[1..1]	Code
2.16		Or}	+ + + + Proprietary	<Prtry>	[1..1]	Text
2.17			+ + RequestedExecutionDate	<ReqdExctnDt>	[1..1]	Date
2.19			+ + Debtor	<Dbtr>	[1..1]	+
2.19	9.1.0		+ + + Name	<Nm>	[0..1]	Text
2.19	9.1.1		+ + + PostalAddress	<PstlAdr>	[0..1]	
2.19	9.1.10		+ + + + Country	<Ctry>	[0..1]	Code
2.19	9.1.11		+ + + + AddressLine	<AdrLine>	[0..7]	Text
2.19	9.1.12		+ + + Identification	<Id>	[0..1]	
2.19	9.1.13	{Or	+ + + + OrganisationIdentification	<OrgId>	[1..1]	
2.19	9.1.14		+ + + + + BICOrBEI	<BICOrBEI>	[0..1]	Identifijer
2.19	9.1.15		+ + + + + Other	<Othr>	[0..n]	
2.19	9.1.16		+ + + + + Identification	<Id>	[1..1]	Text
2.19	9.1.17		+ + + + + SchemeName	<SchmeNm>	[0..1]	
2.19	9.1.18	{Or	+ + + + + + Code	<Cd>	[1..1]	Code



<b>Index</b>	<b>Generic ISO Index</b>	<b>Or</b>	<b>Message Item</b>	<b>&lt;XML Tag&gt;</b>	<b>Mult.</b>	<b>Type</b>
2.19	9.1.19	Or}}	+++++++ Proprietary	<Prtry>	[1..1]	Text
2.19	9.1.20		+++++++ Issuer	<Issr>	[0..1]	Text
2.19	9.1.21	Or}	++++ PrivateIdentification	<PrvtId>	[1..1]	
2.19	9.1.22		+++++ DateAndPlaceOfBirth	<DtAndPlcOfBirth>	[0..1]	
2.19	9.1.23		+++++++ BirthDate	<BirthDt>	[1..1]	Date
2.19	9.1.24		+++++++ ProvinceOfBirth	<PrvcOfBirth>	[0..1]	Text
2.19	9.1.25		+++++++ CityOfBirth	<CityOfBirth>	[1..1]	Text
2.19	9.1.26		+++++++ CountryOfBirth	<CtryOfBirth>	[1..1]	Code
2.19	9.1.27		+++++ Other	<Othr>	[0..n]	
2.19	9.1.28		+++++++ Identification	<Id>	[1..1]	Text
2.19	9.1.29		+++++++ SchemeName	<SchmeNm>	[0..1]	
2.19	9.1.30	{{Or	+++++++ Code	<Cd>	[1..1]	Code
2.19	9.1.31	Or}}	+++++++ Proprietary	<Prtry>	[1..1]	Text
2.19	9.1.32		+++++++ Issuer	<Issr>	[0..1]	Text
2.20			++ DebtorAccount	<DbtrAcct>	[1..1]	+
2.20	1.1.0		+++ Identification	<Id>	[1..1]	
2.20	1.1.1	{Or	++++ IBAN	<IBAN>	[1..1]	Identifier
2.20	1.1.11		+++ Currency	<Ccy>	[0..1]	Code
2.21			++ DebtorAgent	<DbtrAgt>	[1..1]	+
2.21	6.1.0		+++ FinancialInstitutionIdentification	<FinInstnId>	[1..1]	
2.21	6.1.1	{Or	++++ BIC	<BIC>	[0..1]	Identifier
2.21	6.1.19	Or}	++++ Other	<Othr>	[0..1]	
2.21	6.1.20		+++++ Identification	<Id>	[1..1]	Text
2.23			++ UltimateDebtor	<UltmtDbtr>	[0..1]	+
2.23	9.1.0		+++ Name	<Nm>	[0..1]	Text
2.23	9.1.12		+++ Identification	<Id>	[0..1]	
2.23	9.1.13	{Or	++++ OrganisationIdentification	<OrgId>	[1..1]	
2.23	9.1.14		+++++ BICOrBEI	<BICOrBEI>	[0..1]	Identifier
2.23	9.1.15		+++++ Other	<Othr>	[0..n]	
2.23	9.1.16		+++++++ Identification	<Id>	[1..1]	Text
2.23	9.1.17		+++++++ SchemeName	<SchmeNm>	[0..1]	
2.23	9.1.18	{{Or	+++++++ Code	<Cd>	[1..1]	Code
2.23	9.1.19	Or}}	+++++++ Proprietary	<Prtry>	[1..1]	Text

<b>Index</b>	<b>Generic ISO Index</b>	<b>Or</b>	<b>Message Item</b>	<b>&lt;XML Tag&gt;</b>	<b>Mult.</b>	<b>Type</b>
2.23	9.1.20		+++++ Issuer	<Issr>	[0..1]	Text
2.23	9.1.21	Or}	++++ PrivateIdentification	<PrvtId>	[1..1]	
2.23	9.1.22		+++++ DateAndPlaceOfBirth	<DtAndPlcOfBirth>	[0..1]	
2.23	9.1.23		+++++ BirthDate	<BirthDt>	[1..1]	Date
2.23	9.1.24		+++++ ProvinceOfBirth	<PrvcOfBirth>	[0..1]	Text
2.23	9.1.25		+++++ CityOfBirth	<CityOfBirth>	[1..1]	Text
2.23	9.1.26		+++++ CountryOfBirth	<CtryOfBirth>	[1..1]	Code
2.23	9.1.27		+++++ Other	<Othr>	[0..n]	
2.23	9.1.28		+++++ Identification	<Id>	[1..1]	Text
2.23	9.1.29		+++++ SchemeName	<SchmeNm>	[0..1]	
2.23	9.1.30	{{Or	+++++ Code	<Cd>	[1..1]	Code
2.23	9.1.31	Or}}	+++++ Proprietary	<Prtry>	[1..1]	Text
2.23	9.1.32		+++++ Issuer	<Issr>	[0..1]	Text
2.24			++ ChargeBearer	<ChrgBr>	[0..1]	Code
2.27			++ CreditTransferTransactionInformation	<CdtTrfTxInf>	[1..n]	
2.28			+++ PaymentIdentification	<PmtId>	[1..1]	
2.29			++++ InstructionIdentification	<InstrId>	[0..1]	Text
2.30			++++ EndToEndIdentification	<EndToEndId>	[1..1]	Text
2.31			+++ PaymentTypeInformation	<PmtTplnf>	[0..1]	
2.33			++++ ServiceLevel	<SvcLvl>	[0..1]	
2.34		{Or	++++ Code	<Cd>	[1..1]	Code
2.36			++++ LocalInstrument	<LclInstrm>	[0..1]	
2.37		{Or	++++ Code	<Cd>	[1..1]	Code
2.38		Or}	++++ Proprietary	<Prtry>	[1..1]	Text
2.39			++++ CategoryPurpose	<CtgyPurp>	[0..1]	
2.40		{Or	++++ Code	<Cd>	[1..1]	Code
2.41		Or}	++++ Proprietary	<Prtry>	[1..1]	Text
2.42			+++ Amount	<Amt>	[1..1]	
2.43		{Or	++++ InstructedAmount	<InstdAmt>	[1..1]	Amount
2.51			+++ ChargeBearer	<ChrgBr>	[0..1]	Code
2.70			+++ UltimateDebtor	<UltmtDbtr>	[0..1]	+
2.70	9.1.0		+++Name	<Nm>	[0..1]	Text
2.70	9.1.12		+++ Identification	<Id>	[0..1]	

<b>Index</b>	<b>Generic ISO Index</b>	<b>Or</b>	<b>Message Item</b>	<b>&lt;XML Tag&gt;</b>	<b>Mult.</b>	<b>Type</b>
2.70	9.1.13	{Or	++++ OrganisationIdentification	<OrgId>	[1..1]	
2.70	9.1.14		+++++ BICOrBEI	<BICOrBEI>	[0..1]	Identifier
2.70	9.1.15		+++++ Other	<Othr>	[0..n]	
2.70	9.1.16		+++++ Identification	<Id>	[1..1]	Text
2.70	9.1.17		+++++ SchemeName	<SchmeNm>	[0..1]	
2.70	9.1.18	{{Or	+++++++ Code	<Cd>	[1..1]	Code
2.70	9.1.19	Or}}	+++++++ Proprietary	<Prtry>	[1..1]	Text
2.70	9.1.20		+++++++ Issuer	<Issr>	[0..1]	Text
2.70	9.1.21	Or}	++++ PrivateIdentification	<PrvtId>	[1..1]	
2.70	9.1.22		+++++ DateAndPlaceOfBirth	<DtAndPlcOfBirth>	[0..1]	
2.70	9.1.23		+++++ BirthDate	<BirthDt>	[1..1]	Date
2.70	9.1.24		+++++ ProvinceOfBirth	<PrvcOfBirth>	[0..1]	Text
2.70	9.1.25		+++++ CityOfBirth	<CityOfBirth>	[1..1]	Text
2.70	9.1.26		+++++ CountryOfBirth	<CtryOfBirth>	[1..1]	Code
2.70	9.1.27		+++++ Other	<Othr>	[0..n]	
2.70	9.1.28		+++++ Identification	<Id>	[1..1]	Text
2.70	9.1.29		+++++ SchemeName	<SchmeNm>	[0..1]	
2.70	9.1.30	{{Or	+++++++ Code	<Cd>	[1..1]	Code
2.70	9.1.31	Or}}	+++++++ Proprietary	<Prtry>	[1..1]	Text
2.70	9.1.32		+++++++ Issuer	<Issr>	[0..1]	Text
2.77			+++ CreditorAgent	<CdtrAgt>	[0..1]	+
2.77	6.1.0		++++ FinancialInstitutionIdentification	<FinInstnId>	[1..1]	
2.77	6.1.1		+++++ BIC	<BIC>	[0..1]	Identifier
2.79			+++ Creditor	<Cdtr>	[0..1]	+
2.79	9.1.0		++++ Name	<Nm>	[0..1]	Text
2.79	9.1.1		++++ PostalAddress	<PstAdr>	[0..1]	
2.79	9.1.10		+++++ Country	<Ctry>	[0..1]	Code
2.79	9.1.11		+++++ AddressLine	<AdrLine>	[0..7]	Text
2.79	9.1.12		++++ Identification	<Id>	[0..1]	
2.79	9.1.13	{Or	+++++ OrganisationIdentification	<OrgId>	[1..1]	
2.79	9.1.14		+++++ BICOrBEI	<BICOrBEI>	[0..1]	Identifier
2.79	9.1.15		+++++ Other	<Othr>	[0..n]	
2.79	9.1.16		+++++ Identification	<Id>	[1..1]	Text

<b>Index</b>	<b>Generic ISO Index</b>	<b>Or</b>	<b>Message Item</b>	<b>&lt;XML Tag&gt;</b>	<b>Mult.</b>	<b>Type</b>
2.79	9.1.17		+++++ SchemeName	<SchmeNm>	[0..1]	
2.79	9.1.18	{{Or	+++++++ Code	<Cd>	[1..1]	Code
2.79	9.1.19	Or}}	+++++++ Proprietary	<Prtry>	[1..1]	Text
2.79	9.1.20		+++++++ Issuer	<lssr>	[0..1]	Text
2.79	9.1.21	Or}	+++++ PrivateIdentification	<PrvtId>	[1..1]	
2.79	9.1.22		+++++ DateAndPlaceOfBirth	<DtAndPlcOfBirth>	[0..1]	
2.79	9.1.23		+++++++ BirthDate	<BirthDt>	[1..1]	Date
2.79	9.1.24		+++++++ ProvinceOfBirth	<PrvcOfBirth>	[0..1]	Text
2.79	9.1.25		+++++++ CityOfBirth	<CityOfBirth>	[1..1]	Text
2.79	9.1.26		+++++++ CountryOfBirth	<CtryOfBirth>	[1..1]	Code
2.79	9.1.27		+++++ Other	<Othr>	[0..n]	
2.79	9.1.28		+++++++ Identification	<Id>	[1..1]	Text
2.79	9.1.29		+++++++ SchemeName	<SchmeNm>	[0..1]	
2.79	9.1.30	{{Or	+++++++ Code	<Cd>	[1..1]	Code
2.79	9.1.31	Or}}	+++++++ Proprietary	<Prtry>	[1..1]	Text
2.79	9.1.32		+++++++ Issuer	<lssr>	[0..1]	Text
2.80			+++ CreditorAccount	<CdtrAcct>	[0..1]	+
2.80	1.1.0		+++ Identification	<Id>	[1..1]	
2.80	1.1.1	{Or	++++ IBAN	<IBAN>	[1..1]	Identifier
2.81			+++ UltimateCreditor	<UltmtCdtr>	[0..1]	+
2.81	9.1.0		++++ Name	<Nm>	[0..1]	Text
2.81	9.1.12		++++ Identification	<Id>	[0..1]	
2.81	9.1.13	{Or	+++++ OrganisationIdentification	<OrgId>	[1..1]	
2.81	9.1.14		+++++ BICOrBEI	<BICOrBEI>	[0..1]	Identifier
2.81	9.1.15		+++++ Other	<Othr>	[0..n]	
2.81	9.1.16		+++++++ Identification	<Id>	[1..1]	Text
2.81	9.1.17		+++++++ SchemeName	<SchmeNm>	[0..1]	
2.81	9.1.18	{{Or	+++++ Code	<Cd>	[1..1]	Code
2.81	9.1.19	Or}}	+++++++ Proprietary	<Prtry>	[1..1]	Text
2.81	9.1.20		+++++++ Issuer	<lssr>	[0..1]	Text
2.81	9.1.21	Or}	+++++ PrivateIdentification	<PrvtId>	[1..1]	
2.81	9.1.22		+++++ DateAndPlaceOfBirth	<DtAndPlcOfBirth>	[0..1]	
2.81	9.1.23		+++++++ BirthDate	<BirthDt>	[1..1]	Date

<i>Index</i>	<i>Generic ISO Index</i>	<i>Or</i>	<i>Message Item</i>	<i>&lt;XML Tag&gt;</i>	<i>Mult.</i>	<i>Type</i>
2.81	9.1.24		+++++++ ProvinceOfBirth	<PrvcOfBirth>	[0..1]	Text
2.81	9.1.25		+++++++ CityOfBirth	<CityOfBirth>	[1..1]	Text
2.81	9.1.26		+++++++ CountryOfBirth	<CtryOfBirth>	[1..1]	Code
2.81	9.1.27		+++++++ Other	<Othr>	[0..n]	
2.81	9.1.28		+++++++ Identification	<Id>	[1..1]	Text
2.81	9.1.29		+++++++ SchemeName	<SchmeNm>	[0..1]	
2.81	9.1.30	{{Or	+++++++ Code	<Cd>	[1..1]	Code
2.81	9.1.31	Or}}	+++++++ Proprietary	<Prtry>	[1..1]	Text
2.81	9.1.32		+++++++ Issuer	<Issr>	[0..1]	Text
2.86			+++ Purpose	<Purp>	[0..1]	
2.87		{Or	++++ Code	<Cd>	[1..1]	
2.98			+++ RemittanceInformation	<RmtInf>	[0..1]	
2.99			++++ Unstructured	<Ustrd>	[0..n]	Text
2,100			++++ Structured	<Strd>	[0..n]	
2,120			+++++ CreditorReferenceInformation	<CdtrRefInf>	[0..1]	
2,121			+++++ Type	<Tp>	[0..1]	
2,122			+++++++ CodeOrProprietary	<CdOrPrtry>	[1..1]	
2,123		{Or	+++++++ Code	<Cd>	[1..1]	Code
2,125			+++++++ Issuer	<Issr>	[0..1]	Text
2,126			+++++++ Reference	<Ref>	[0..1]	Text

## Annex B Clieop03 equivalent

<b>Index</b>	<b>Generic Index</b>	<b>&lt;XML Tag&gt;</b>	<b>Clieop03 functional equivalent</b>
1.1		<MsgId>	0001-04
1.2		<CreDtTm>	0001-03
1.6		<NbOfTx>	9990-05
1.7		<CtrlSum>	9990-03
1.8	9.1.0	<Nm>	0030-05
2.17		<ReqdExctnDt>	0030-04
2.19	9.1.0	<Nm>	0110-03
2.21	6.1.1	<BIC>	0010-05
2.43		<InstdAmt>	0100-04
2.79	9.1.0	<Nm>	0170-03
2.79	9.1.11	<AdrLine>	0173-03
2.80	1.1.1	<IBAN>	0100-06
2.99		<Ustrd>	0160-03

## Annex C Rulebook attribute equivalent

<i>Index</i>	<i>Generic Index</i>	<i>&lt;XML Tag&gt;</i>	<i>Rulebook attribute equivalent</i>
2.9		<Cd>	AT-40 Identification code of the Scheme
2.14		<CtgyPurp>	AT-45 Category purpose of the Credit Transfer
2.19	9.1.0	<Nm>	AT-02 Name of the Originator
2.19	9.1.1	<PstlAdr>	AT-03 Address of the Originator
2.19	9.1.12	<Id>	AT-10 Originator Identification Code
2.21		<DbtrAgt>	AT-06 BIC code of the Originator Bank
2.23	9.1.0	<Nm>	AT-08 Name of the Originator Reference Party
2.23	9.1.12	<Id>	AT-09 Identification code of the Originator Reference Party
2.30		<EndToEndId>	AT-41 Originator's Reference to the Credit Transfer
2.34		<Cd>	AT-40 Identification code of the Scheme
2.39		<CtgyPurp>	AT-45 Category purpose of the Credit Transfer
2.43		<InstdAmt>	AT-04 Amount of the Credit Transfer in Euro
2.70	9.1.0	<Nm>	AT-08 Name of the Originator Reference Party.
2.70	9.1.12	<Id>	AT-09 Identification code of the Originator Reference Party
2.77		<CdtrAgt>	AT-23 BIC of the Beneficiary Bank
2.79	9.1.0	<Nm>	AT-21 Name of the Beneficiary
2.79	9.1.1	<PstlAdr>	AT-22 Address of the Beneficiary
2.79	9.1.12	<Id>	AT-24 Beneficiary Identification Code
2.80		<CdtrAcct>	AT-20 Account number of the Beneficiary
2.81	9.1.0	<Nm>	AT-28 Name of the Beneficiary Reference Party
2.81	9.1.12	<Id>	AT-29 Identification Code of the Beneficiary Reference Party.
2.86		<Purp>	AT-44 Purpose of the Credit Transfer
2.98		<RmtInf>	AT-05 Remittance Information

## Annex D Overview ISO codes

The ISO 20022 Payment messages use 'external code lists' which are validated and approved by the Payments SEG.

The listed code values can be used in specific elements of the payments messages as indicated in the documents below. Unlike other ISO 20022 code lists, the code values are not included in the XML message schema with the message element they type. The purpose of externalising these code values is to be able to update the code lists (e.g. add new code values) without impacting the message themselves and, hence, without requiring the development of a new version of the messages that use these code lists.

25 external code lists are published in a spreadsheet which is versioned at three levels: the spreadsheet itself has a publication date, each list within the spreadsheet has a publication date (see 'CodeInventory' sheet) and each individual code value has a date of last update ('status date').

See [www.iso20022.org](http://www.iso20022.org), under “External Code Lists, Data Source Schemes (DSS), Variants and Supplementary Data”, with “External Code Lists spreadsheet” as reference ([http://www.iso20022.org/External\\_Code\\_Lists\\_and\\_DSS.page](http://www.iso20022.org/External_Code_Lists_and_DSS.page)).



## Annex E Generic ISO message Items

<b>Index</b>		<b>Message item</b>	<b>XML tag</b>	<b>Mult.</b>	<b>Type</b>
<b>1.1</b>		<b>CashAccount16</b>			
1.1.0		Identification	<Id>	[1..1]	
1.1.1	{Or	+ IBAN	<IBAN>	[1..1]	Identificer
1.1.2	Or}	+ Other	<Othr>	[1..1]	
1.1.3		+ + Identification	<Id>	[1..1]	Text
1.1.4		+ + SchemeName	<SchmeNm>	[0..1]	
1.1.5	{{Or	+ + + Code	<Cd>	[1..1]	Code
1.1.6	Or}}	+ + + Proprietary	<Prtry>	[1..1]	Text
1.1.7		+ + Issuer	<Issr>	[0..1]	Text
1.1.8		Type	<Tp>	[0..1]	
1.1.9	{Or	+ Code	<Cd>	[1..1]	Code
1.1.10	Or}	+ Proprietary	<Prtry>	[1..1]	Text
1.1.11		Currency	<Ccy>	[0..1]	Code
1.1.12		Name	<Nm>	[0..1]	Text
<b>2.1</b>		<b>AmountAndCurrencyExchange3</b>			
2.1.0		InstructedAmount	<InstdAmt>	[0..1]	
2.1.1		Amount	<Amt>	[1..1]	Amount
2.1.2		CurrencyExchange	<CcyXchg>	[0..1]	
2.1.3		SourceCurrency	<SrcCcy>	[1..1]	Code
2.1.4		TargetCurrency	<TrgtCcy>	[0..1]	Code
2.1.5		UnitCurrency	<UnitCcy>	[0..1]	Code
2.1.6		ExchangeRate	<XchgRate>	[1..1]	Rate
2.1.7		ContractIdentification	<CtrctId>	[0..1]	Text
2.1.8		QuotationDate	<QtnDt>	[0..1]	Date
2.1.9		TransactionAmount	<TxAmt>	[0..1]	
2.1.10		Amount	<Amt>	[1..1]	Amount
2.1.11		CurrencyExchange	<CcyXchg>	[0..1]	
2.1.12		SourceCurrency	<SrcCcy>	[1..1]	Code
2.1.13		TargetCurrency	<TrgtCcy>	[0..1]	Code
2.1.14		UnitCurrency	<UnitCcy>	[0..1]	Code
2.1.15		ExchangeRate	<XchgRate>	[1..1]	Rate

<b>Index</b>		<b>Message item</b>	<b>XML tag</b>	<b>Mult.</b>	<b>Type</b>
2.1.16		ContractIdentification	<CtrctId>	[0..1]	Text
2.1.17		QuotationDate	<QtnDt>	[0..1]	Date
2.1.18		CounterValueAmount	<CtrValAmt>	[0..1]	
2.1.19		Amount	<Amt>	[1..1]	Amount
2.1.20		CurrencyExchange	<CcyXchg>	[0..1]	
2.1.21		SourceCurrency	<SrcCcy>	[1..1]	Code
2.1.22		TargetCurrency	<TrgtCcy>	[0..1]	Code
2.1.23		UnitCurrency	<UnitCcy>	[0..1]	Code
2.1.24		ExchangeRate	<XchgRate>	[1..1]	Rate
2.1.25		ContractIdentification	<CtrctId>	[0..1]	Text
2.1.26		QuotationDate	<QtnDt>	[0..1]	Date
2.1.27		AnnouncedPostingAmount	<AnnCdPstngAmt>	[0..1]	
2.1.28		Amount	<Amt>	[1..1]	Amount
2.1.29		CurrencyExchange	<CcyXchg>	[0..1]	
2.1.30		SourceCurrency	<SrcCcy>	[1..1]	Code
2.1.31		TargetCurrency	<TrgtCcy>	[0..1]	Code
2.1.32		UnitCurrency	<UnitCcy>	[0..1]	Code
2.1.33		ExchangeRate	<XchgRate>	[1..1]	Rate
2.1.34		ContractIdentification	<CtrctId>	[0..1]	Text
2.1.35		QuotationDate	<QtnDt>	[0..1]	Date
2.1.36		ProprietaryAmount	<PrtryAmt>	[0..n]	
2.1.37		Type	<Tp>	[1..1]	Text
2.1.38		Amount	<Amt>	[1..1]	Amount
2.1.39		CurrencyExchange	<CcyXchg>	[0..1]	
2.1.40		SourceCurrency	<SrcCcy>	[1..1]	Code
2.1.41		TargetCurrency	<TrgtCcy>	[0..1]	Code
2.1.42		UnitCurrency	<UnitCcy>	[0..1]	Code
2.1.43		ExchangeRate	<XchgRate>	[1..1]	Rate
2.1.44		ContractIdentification	<CtrctId>	[0..1]	Text
2.1.45		QuotationDate	<QtnDt>	[0..1]	Date
3.1		CurrencyAndAmountRange2			
3.1.0		Amount	<Amt>	[1..1]	
3.1.1	{Or	+ FromAmount	<FrAmt>	[1..1]	
3.1.2		++ BoundaryAmount	<BdryAmt>	[1..1]	Amount
3.1.3		++ Included	<Incl>	[1..1]	Indicator

<b>Index</b>		<b>Message item</b>	<b>XML tag</b>	<b>Mult.</b>	<b>Type</b>
3.1.4	Or	+ ToAmount	<ToAmt>	[1..1]	
3.1.5		++ BoundaryAmount	<BdryAmt>	[1..1]	Amount
3.1.6		++ Included	<Incl>	[1..1]	Indicator
3.1.7	Or	FromToAmount	<FrToAmt>	[1..1]	
3.1.8		+ FromAmount	<FrAmt>	[1..1]	
3.1.9		++ BoundaryAmount	<BdryAmt>	[1..1]	Amount
3.1.10		++ Included	<Incl>	[1..1]	Indicator
3.1.11		+ ToAmount	<ToAmt>	[1..1]	
3.1.12		++ BoundaryAmount	<BdryAmt>	[1..1]	Amount
3.1.13		++ Included	<Incl>	[1..1]	Indicator
3.1.14	Or	+ EqualAmount	<EQAmt>	[1..1]	Amount
3.1.15	Or}	+ NotEqualAmount	<NEQAmt>	[1..1]	Amount
3.1.16		CreditDebitIndicator	<CdtDbtInd>	[0..1]	Code
3.1.17		Currency	<Ccy>	[1..1]	Code
4.1		DateAndDateTimeChoice			
4.1.0	{Or	Date	<Dt>	[1..1]	Date
4.1.1	Or}	DateTime	<DtTm>	[1..1]	DateTime
5.1		DateTimePeriodDetails			
5.1.0		FromDateTime	<FrDtTm>	[1..1]	DateTime
5.1.1		ToDateTime	<ToDtTm>	[1..1]	DateTime
6.1		BranchAndFinancialInstitutionIdentification4			
6.1.0		FinancialInstitutionIdentification	<FinInstnId>	[1..1]	
6.1.1		+ BIC	<BIC>	[0..1]	Identifier
6.1.2		+ ClearingSystemMemberIdentification	<ClrSysMmbld>	[0..1]	
6.1.3		++ ClearingSystemIdentification	<ClrSysId>	[0..1]	
6.1.4		+++ Code	<Cd>	[1..1]	Code
6.1.5		+++ Proprietary	<Prtry>	[1..1]	Text
6.1.6		++ MemberIdentification	<Mmbld>	[1..1]	Text
6.1.7	{Or	+ Name	<Nm>	[0..1]	Text
6.1.8	{Or	+ PostalAddress	<PstlAdr>	[0..1]	
6.1.9	Or}	++ AddressType	<AdrTp>	[0..1]	Code
6.1.10	Or}	++ Department	<Dept>	[0..1]	Text
6.1.11		++ SubDepartment	<SubDept>	[0..1]	Text
6.1.12		++ StreetName	<StrtNm>	[0..1]	Text
6.1.13		++ BuildingNumber	<BldgNb>	[0..1]	Text

<b>Index</b>		<b>Message item</b>	<b>XML tag</b>	<b>Mult.</b>	<b>Type</b>
6.1.14		++ PostCode	<PstCd>	[0..1]	Text
6.1.15		++ TownName	<TwnNm>	[0..1]	Text
6.1.16		++ CountrySubDivision	<CtrySubDvsn>	[0..1]	Text
6.1.17		++ Country	<Ctry>	[0..1]	Code
6.1.18		++ AddressLine	<AdrLine>	[0..7]	Text
6.1.19		+ Other	<Othr>	[0..1]	
6.1.20		++ Identification	<Id>	[1..1]	Text
6.1.21		++ SchemeName	<SchmeNm>	[0..1]	
6.1.22		+++ Code	<Cd>	[1..1]	Code
6.1.23		+++ Proprietary	<Prtry>	[1..1]	Text
6.1.24		++ Issuer	<Issr>	[0..1]	Text
6.1.25		BranchIdentification	<BrnchId>	[0..1]	
6.1.26		+ Identification	<Id>	[0..1]	Text
6.1.27		+ Name	<Nm>	[0..1]	Text
6.1.28		++ PostalAddress	<PstlAdr>	[0..1]	
6.1.29		++ AddressType	<AdrTp>	[0..1]	Code
6.1.30		++ Department	<Dept>	[0..1]	Text
6.1.31	{Or	++ SubDepartment	<SubDept>	[0..1]	Text
6.1.32	Or}	++ StreetName	<StrtNm>	[0..1]	Text
6.1.33		++ BuildingNumber	<BldgNb>	[0..1]	Text
6.1.34		++ PostCode	<PstCd>	[0..1]	Text
6.1.35		++ TownName	<TwnNm>	[0..1]	Text
6.1.36		++ CountrySubDivision	<CtrySubDvsn>	[0..1]	Text
6.1.37		++ Country	<Ctry>	[0..1]	Code
6.1.38		++ AddressLine	<AdrLine>	[0..7]	Text
7.1		GenericIdentification3			
7.1.0		Identification	<Id>	[1..1]	Text
7.1.1		Issuer	<Issr>	[0..1]	Text
8.1		Pagination			
8.1.0		PageNumber	<PgNb>	[1..1]	Text
8.1.1		LastPageIndicator	<LastPgInd>	[1..1]	Indicator
9.1		PartyIdentification32			
9.1.0		Name	<Nm>	[0..1]	Text
9.1.1		PostalAddress	<PstlAdr>	[0..1]	
9.1.2		+ AddressType	<AdrTp>	[0..1]	Code

<b>Index</b>		<b>Message item</b>	<b>XML tag</b>	<b>Mult.</b>	<b>Type</b>
9.1.3		+ Department	<Dept>	[0..1]	Text
9.1.4		+ SubDepartment	<SubDept>	[0..1]	Text
9.1.5		+ StreetName	<StrtNm>	[0..1]	Text
9.1.6		+ BuildingNumber	<BldgNb>	[0..1]	Text
9.1.7		+ PostCode	<PstCd>	[0..1]	Text
9.1.8		+ TownName	<TwnNm>	[0..1]	Text
9.1.9		+ CountrySubDivision	<CtrySubDvsn>	[0..1]	Text
9.1.10		+ Country	<Ctry>	[0..1]	Code
9.1.11		+ AddressLine	<AdrLine>	[0..7]	Text
9.1.12		Identification	<Id>	[0..1]	
9.1.13		+ OrganisationIdentification	<OrgId>	[1..1]	
9.1.14		+ + BICOrBEI	<BICOrBEI>	[0..1]	Identifier
9.1.15		+ + Other	<Othr>	[0..n]	
9.1.16		+ + + Identification	<Id>	[1..1]	Text
9.1.17		+ + + SchemeName	<SchmeNm>	[0..1]	
9.1.18		+ + + + Code	<Cd>	[1..1]	Code
9.1.19		+ + + + Proprietary	<Prtry>	[1..1]	Text
9.1.20		+ + + Issuer	<Issr>	[0..1]	Text
9.1.21		+ PrivateIdentification	<PrvtId>	[1..1]	
9.1.22		+ + DateAndPlaceOfBirth	<DtAndPlcOfBirth>	[0..1]	
9.1.23	{Or	+ + + BirthDate	<BirthDt>	[1..1]	Date
9.1.24	{Or	+ + + ProvinceOfBirth	<PrvcOfBirth>	[0..1]	Text
9.1.25		+ + + CityOfBirth	<CityOfBirth>	[1..1]	Text
9.1.26		+ + + CountryOfBirth	<CtryOfBirth>	[1..1]	Code
9.1.27		+ + Other	<Othr>	[0..n]	
9.1.28		+ + + Identification	<Id>	[1..1]	Text
9.1.29		+ + + SchemeName	<SchmeNm>	[0..1]	
9.1.30		+ + + + Code	<Cd>	[1..1]	Code
9.1.31		+ + + + Proprietary	<Prtry>	[1..1]	Text
9.1.32		+ + + Issuer	<Issr>	[0..1]	Text
9.1.33		CountryOfResidence	<CtryOfRes>	[0..1]	Code
9.1.34	{{Or	ContactDetails	<CtctDtls>	[0..1]	
9.1.35	{Or	+ NamePrefix	<NmPrfx>	[0..1]	Code
9.1.36	Or}}	+ Name	<Nm>	[0..1]	Text
9.1.37	Or}	+ PhoneNumber	<PhneNb>	[0..1]	Text

<b>Index</b>		<b>Message item</b>	<b>XML tag</b>	<b>Mult.</b>	<b>Type</b>
9.1.38		+ <i>MobileNumber</i>	<MobNb>	[0..1]	Text
9.1.39		+ <i>FaxNumber</i>	<FaxNb>	[0..1]	Text
9.1.40	Or}	+ <i>EmailAddress</i>	<EmailAdr>	[0..1]	Text
9.1.41	Or}	+ <i>Other</i>	<Othr>	[0..1]	Text
<b>10.1</b>		<b><i>PostalAddress6</i></b>			
10.1.0		<i>AddressType</i>	<AdrTp>	[0..1]	Code
10.1.1		<i>Department</i>	<Dept>	[0..1]	Text
10.1.2		<i>SubDepartment</i>	<SubDept>	[0..1]	Text
10.1.3		<i>StreetName</i>	<StrtNm>	[0..1]	Text
10.1.4		<i>BuildingNumber</i>	<BldgNb>	[0..1]	Text
10.1.5		<i>PostCode</i>	<PstCd>	[0..1]	Text
10.1.6		<i>TownName</i>	<TwnNm>	[0..1]	Text
10.1.7		<i>CountrySubDivision</i>	<CtrySubDvsn>	[0..1]	Text
10.1.8		<i>Country</i>	<Ctry>	[0..1]	Code
10.1.9		<i>AddressLine</i>	<AdrLine>	[0..7]	Text
<b>11.1</b>		<b><i>RegulatoryReporting3</i></b>			
11.1.0		<i>DebitCreditReportingIndicator</i>	<DbtCdtRptgInd>	[0..1]	Code
11.1.1		<i>Authority</i>	<Authrty>	[0..1]	
11.1.2		+ <i>Name</i>	<Nm>	[0..1]	Text
11.1.3		+ <i>Country</i>	<Ctry>	[0..1]	Code
11.1.4		<i>Details</i>	<Dtls>	[0..n]	
11.1.5		+ <i>Type</i>	<Tp>	[0..1]	Text
11.1.6		+ <i>Date</i>	<Dt>	[0..1]	Date
11.1.7		+ <i>Country</i>	<Ctry>	[0..1]	Code
11.1.8		+ <i>Code</i>	<Cd>	[0..1]	Text
11.1.9		+ <i>Amount</i>	<Amt>	[0..1]	Amount
11.1.10		+ <i>Information</i>	<Inf>	[0..n]	Text
<b>12.1</b>		<b><i>FinancialInstrumentQuantityChoice</i></b>			
12.1.0	{Or	<i>Unit</i>	<Unit>	[1..1]	Quantity
12.1.1	Or	<i>FaceAmount</i>	<FaceAmt>	[1..1]	Amount
12.1.2	Or}	<i>AmortisedValue</i>	<AmtsdVal>	[1..1]	Amount
<b>13.1</b>		<b><i>TaxInformation3</i></b>			
13.1.0		<i>Creditor</i>	<Cdtr>	[0..1]	
13.1.1		+ <i>TaxIdentification</i>	<TaxId>	[0..1]	Text
13.1.2		+ <i>RegistrationIdentification</i>	<RegnId>	[0..1]	Text

<b>Index</b>	<b>Message item</b>	<b>XML tag</b>	<b>Mult.</b>	<b>Type</b>
13.1.3	+ TaxType	<TaxTp>	[0..1]	Text
13.1.4	Debtor	<Dbtr>	[0..1]	
13.1.5	+ TaxIdentification	<TaxId>	[0..1]	Text
13.1.6	+ RegistrationIdentification	<RegnId>	[0..1]	Text
13.1.7	+ TaxType	<TaxTp>	[0..1]	Text
13.1.8	+ Authorisation	<Authstn>	[0..1]	
13.1.9	+ + Title	<Titl>	[0..1]	Text
13.1.10	+ + Name	<Nm>	[0..1]	Text
13.1.11	AdministrationZone	<AdmstnZn>	[0..1]	Text
13.1.12	ReferenceNumber	<RefNb>	[0..1]	Text
13.1.13	Method	<Mtd>	[0..1]	Text
13.1.14	TotalTaxableBaseAmount	<TtITaxblBaseAmt>	[0..1]	Amount
13.1.15	TotalTaxAmount	<TtITaxAmt>	[0..1]	Amount
13.1.16	Date	<Dt>	[0..1]	Date
13.1.17	SequenceNumber	<SeqNb>	[0..1]	Quantity
13.1.18	Record	<Rcrd>	[0..n]	
13.1.19	+ Type	<Tp>	[0..1]	Text
13.1.20	+ Category	<Ctgy>	[0..1]	Text
13.1.21	+ CategoryDetails	<CtgyDtls>	[0..1]	Text
13.1.22	+ DebtorStatus	<DbtrSts>	[0..1]	Text
13.1.23	+ CertificateIdentification	<CertId>	[0..1]	Text
13.1.24	+ FormsCode	<FrmsCd>	[0..1]	Text
13.1.25	+ Period	<Prd>	[0..1]	
13.1.26	+ + Year	<Yr>	[0..1]	Date
13.1.27	+ + Type	<Tp>	[0..1]	Code
13.1.28	+ + FromToDate	<FrToDt>	[0..1]	
13.1.29	+ + + FromDate	<FrDt>	[1..1]	Date
13.1.30	+ + + ToDate	<ToDt>	[1..1]	Date
13.1.31	+ TaxAmount	<TaxAmt>	[0..1]	
13.1.32	+ + Rate	<Rate>	[0..1]	Rate
13.1.33	+ + TaxableBaseAmount	<TaxblBaseAmt>	[0..1]	Amount
13.1.34	+ + TotalAmount	<TtIAmt>	[0..1]	Amount
13.1.35	+ + + Details	<Dtls>	[0..n]	
13.1.36	+ + + Period	<Prd>	[0..1]	
13.1.37	+ + + + Year	<Yr>	[0..1]	Date

<b>Index</b>		<b>Message item</b>	<b>XML tag</b>	<b>Mult.</b>	<b>Type</b>
13.1.38		+++ Type	<Tp>	[0..1]	Code
13.1.39		+++ FromToDate	<FrToDt>	[0..1]	
13.1.40		+++ FromDate	<FrDt>	[1..1]	Date
13.1.41		+++ ToDate	<ToDt>	[1..1]	Date
13.1.42		++ Amount	<Amt>	[1..1]	Amount
13.1.43		+ AdditionalInformation	<AddtInf>	[0..1]	Text



## Annex F Example message

```
<?xml version="1.0" encoding="UTF-8"?>
<Document xmlns:xsi="http://www.w3.org/2001/XMLSchema-instance"
xmlns="urn:iso:std:iso:20022:tech:xsd:pain.001.001.03"
xsi:schemaLocation="urn:iso:std:iso:20022:tech:xsd:pain.001.001.03 [LOCATION] pain.001.001.03.xsd">
  <CstmrCdtTrfInitn>
    <GrpHdr>
      <MsgId>message-id-001</MsgId>
      <CreDtTm>2010-09-28T14:07:00</CreDtTm>
      <NbOfTxs>2</NbOfTxs>
      <CtrlSum>30.3</CtrlSum>
      <InitgPty>
        <Nm>Bedrijfsnaam</Nm>
      </InitgPty>
    </GrpHdr>
    <PmtInf>
      <PmtInfId>minimaal gevuld</PmtInfId>
      <PmtMtd>TRF</PmtMtd>
      <NbOfTxs>1</NbOfTxs>
      <CtrlSum>10.1</CtrlSum>
      <ReqdExctnDt>2009-11-01</ReqdExctnDt>
      <Dbtr>
        <Nm>Naam</Nm>
      </Dbtr>
      <DbtrAcct>
        <Id>
          <IBAN>NL44RABO0123456789</IBAN>
        </Id>
      </DbtrAcct>
      <DbtrAgt>
        <FinInstnId>
          <BIC>RABONL2U</BIC>
        </FinInstnId>
      </DbtrAgt>
      <CdtTrfTxInf>
        <PmtId>
          <EndToEndId>non ref</EndToEndId>
        </PmtId>
        <Amt>
          <InstdAmt Ccy="EUR">10.1</InstdAmt>
        </Amt>
        <ChrgBr>SLEV</ChrgBr>
        <CdtrAgt>
          <FinInstnId>
            <BIC>ABNANL2A</BIC>
          </FinInstnId>
        </CdtrAgt>
      </CdtTrfTxInf>
    </PmtInf>
  </CstmrCdtTrfInitn>
</Document>
```

```

</CdtrAgt>
<Cdtr>
    <Nm>Naam creditor</Nm>
</Cdtr>
<CdtrAcct>
    <Id>
        <IBAN>NL90ABNA0111111111</IBAN>
    </Id>
</CdtrAcct>
<RmtInf>
    <Ustrd>vrije tekst</Ustrd>
</RmtInf>
</CdtTrfTxInf>
</PmtInf>
<PmtInf>
    <PmtInflId>maximaal gevuld</PmtInflId>
    <PmtMtd>TRF</PmtMtd>
    <BtchBookg>true</BtchBookg>
    <NbOfTxes>1</NbOfTxes>
    <CtrlSum>20.2</CtrlSum>
    <PmtTplInf>
        <InstrPrty>NORM</InstrPrty>
        <SvcLvl>
            <Cd>SEPA</Cd>
        </SvcLvl>
        <LclInstrm>
            <Cd>IDEAL</Cd>
        </LclInstrm>
        <CtgyPurp>
            <Cd>SECU</Cd>
        </CtgyPurp>
    </PmtTplInf>
    <ReqdExctnDt>2009-11-01</ReqdExctnDt>
    <Dbtr>
        <Nm>Naam</Nm>
        <PstlAdr>
            <Ctry>NL</Ctry>
            <AdrLine>Debtor straat 1</AdrLine>
            <AdrLine>9999 XX Plaats debtor</AdrLine>
        </PstlAdr>
    </Dbtr>
    <DbtrAcct>
        <Id>
            <IBAN>NL44RABO0123456789</IBAN>
        </Id>
    </DbtrAcct>
    <DbtrAgt>
        <FinInstnId>
            <BIC>RABONL2U</BIC>
        </FinInstnId>
    </DbtrAgt>

```

```

<UltmtDbtr>
  <Id>
    <OrgId>
      <Othr>
        <Id>12345678</Id>
        <SchmeNm>
          <Prtry>klantnummer</Prtry>
        </SchmeNm>
        <Issr>klantnummer uitgifte instantie</Issr>
      </Othr>
    </OrgId>
  </Id>
</UltmtDbtr>
<ChrgBr>SLEV</ChrgBr>
<CdtTrfTxInf>
  <PmtId>
    <InstrId>debtor-to-debtor-bank-01</InstrId>
    <EndToEndId>End-to-end-id-debtor-to-creditor-01</EndToEndId>
  </PmtId>
  <Amt>
    <InstdAmt Ccy="EUR">20.2</InstdAmt>
  </Amt>
  <CdtrAgt>
    <FinInstnId>
      <BIC>ABNANL2A</BIC>
    </FinInstnId>
  </CdtrAgt>
  <Cdtr>
    <Nm>Naam creditor</Nm>
    <PstlAdr>
      <Ctry>NL</Ctry>
      <AdrLine>Straat creditor 1</AdrLine>
      <AdrLine>9999 XX Plaats creditor</AdrLine>
    </PstlAdr>
  </Cdtr>
  <CdtrAcct>
    <Id>
      <IBAN>NL90ABNA0111111111 </IBAN>
    </Id>
  </CdtrAcct>
  <UltmtCdtr>
    <Id>
      <PrvtId>
        <DtAndPlcOfBirth>
          <BirthDt>1969-07-03</BirthDt>
          <CityOfBirth>PLAATS</CityOfBirth>
          <CtryOfBirth>NL</CtryOfBirth>
        </DtAndPlcOfBirth>
      </PrvtId>
    </Id>
  </UltmtCdtr>

```

```
<Purp>
  <Cd>CHAR</Cd>
</Purp>
<RmtInf>
  <Strd>
    <CdtrRefInf>
      <Tp>
        <CdOrPrtry>
          <Cd>SCOR</Cd>
        </CdOrPrtry>
        <Issr>CUR</Issr>
      </Tp>
      <Ref>1234567</Ref>
    </CdtrRefInf>
  </Strd>
</RmtInf>
</CdtTrfTxInf>
</PmtInf>
</CstmrCdtTrfInitn>
</Document>
```

For an XML-pain.001.001.03 message example go to:

<http://www.betaalvereniging.nl/wp-uploads/2013/01/BvN-pain.001.001.03-example-message.xml>

## Annex G Overview of applicable usage rules

Index	Or	Message Item	Applicable Usage Rules		
			ISO	EPC	NL
		+Message root			
1.0		+GroupHeader			
1.1		++ MessageIdentification	X		
1.2		++ CreationDateTime			
1.6		++ NumberOfTransactions			
1.7		+ +ControlSum			X
1.8		+ + + InitiatingParty	X	X	
1.8		+ + + + Name		X	
1.8		+ + + Identification			
1.8	{Or	+ + + + OrganisationIdentification		X	
1.8		+ + + + + BICOrBEI		X	
1.8		+ + + + + Other		X	
1.8		+ + + + + Identification			
1.8		+ + + + + SchemeName			
1.8	{{Or	+ + + + + + Code			
1.8	Or}}	+ + + + + + Proprietary			
1.8		+ + + + + + Issuer			
1.8	Or}	+ + + + + PrivateIdentification		X	
1.8		+ + + + + DateAndPlaceOfBirth		X	
1.8		+ + + + + BirthDate			
1.8		+ + + + + ProvinceOfBirth			
1.8		+ + + + + CityOfBirth			
1.8		+ + + + + CountryOfBirth			
1.8		+ + + + + Other		X	
1.8		+ + + + + Identification			
1.8		+ + + + + SchemeName			
1.8	{{Or	+ + + + + + Code			
1.8	Or}}	+ + + + + + Proprietary			

Index	Or	Message Item	Applicable Usage Rules		
			ISO	EPC	NL
1.8		+++++ Issuer			
2.0		+ PaymentInformation			
2.1		++ PaymentInformationIdentification			
2.2		++ PaymentMethod		X	
2.3		++ BatchBooking	X	X	
2.4		++ NumberOfTransactions			
2.5		++ ControlSum			X
2.6		++ PaymentTypeInformation		X	
2.7		+++ InstructionPriority		X	
2.8		+++ ServiceLevel		X	
2.9	{Or	++++ Code		X	
2.11		+++ LocalInstrument	X		X
2.12	{Or	++++ Code			X
2.13	Or}	++++ Proprietary			X
2.14		+++ CategoryPurpose	X	X	
2.15	{Or	++++ Code			
2.16	Or}	++++ Proprietary			
2.17		++ RequestedExecutionDate	X		
2.19		++ Debtor		X	
2.19		+++ Name		X	
2.19		+++ PostalAddress			
2.19		++++ Country			
2.19		++++ AddressLine		X	
2.19		+++ Identification			
2.19	{Or	++++ OrganisationIdentification		X	
2.19		+++++ BICOrBEI		X	
2.19		+++++ Other		X	
2.19		+++++ Identification			
2.19		+++++ SchemeName			
2.19	{{Or	+++++ Code			

Index	Or	Message Item	Applicable Usage Rules		
			ISO	EPC	NL
2.19	Or}}	+++++++ Proprietary			
2.19		+++++++ Issuer			
2.19	Or}	++++ PrivateIdentification		X	
2.19		+++++ DateAndPlaceOfBirth		X	
2.19		+++++++ BirthDate			
2.19		+++++++ ProvinceOfBirth			
2.19		+++++++ CityOfBirth			
2.19		+++++++ CountryOfBirth			
2.19		+++++ Other		X	
2.19		+++++++ Identification			
2.19		+++++++ SchemeName			
2.19	{{Or	+++++++ Code			
2.19	Or}}	+++++++ Proprietary			
2.19		+++++++ Issuer			
2.20		++ DebtorAccount		X	
2.20		+++ Identification		X	
2.20	{Or	++++ IBAN		X	
2.20		+++ Currency			
2.21		++ DebtorAgent		X	
2.21		+++ FinancialInstitutionIdentification		X	
2.21		++++ BIC		X	
2.23		++ UltimateDebtor	X	X	
2.23		+++ Name		X	
2.23		+++ Identification			
2.23	{Or	++++ OrganisationIdentification		X	
2.23		+++++ BICOrBEI		X	
2.23		+++++ Other		X	
2.23		+++++++ Identification			
2.23		+++++++ SchemeName			
2.23	{{Or	+++++++ Code			
2.23	Or}}	+++++++ Proprietary			

Index	Or	Message Item	Applicable Usage Rules		
			ISO	EPC	NL
2.23		+++++ Issuer			
2.23	Or}	++++ PrivateIdentification		X	
2.23		++++ DateAndPlaceOfBirth		X	
2.23		+++++ BirthDate			
2.23		+++++ ProvinceOfBirth			
2.23		+++++ CityOfBirth			
2.23		+++++ CountryOfBirth			
2.23		+++++ Other		X	
2.23		+++++ Identification			
2.23		+++++ SchemeName			
2.23	{{Or	+++++ Code			
2.23	Or}}	+++++ Proprietary			
2.23		+++++ Issuer			
2.24		++ ChargeBearer	X	X	
2.27		++ CreditTransferTransactionInformation			
2.28		+++ PaymentIdentification			
2.29		+++ InstructionIdentification	X		
2.30		+++ EndToEndIdentification	X	X	
2.31		+++ PaymentTypeInfoInformation		X	
2.33		+++ ServiceLevel		X	
2.34	{Or	+++++ Code		X	
2.36		+++ LocalInstrument	X		
2.37	{Or	+++++ Code			
2.38	Or}	+++++ Proprietary			
2.39		+++ CategoryPurpose	X	X	
2.40	{Or	+++++ Code			
2.41	Or}	+++++ Proprietary			
2.42		+++ Amount			
2.43	{Or	+++ InstructedAmount	X	X	
2.51		+++ ChargeBearer		X	
2.70		+++ UltimateDebtor		X	



Index	Or	Message Item	Applicable Usage Rules		
			ISO	EPC	NL
2.70		+++Name		X	
2.70		+++ Identification			
2.70	{Or	++++ OrganisationIdentification		X	
2.70		+++++ BICOrBEI		X	
2.70		+++++ Other		X	
2.70		+++++ Identification			
2.70		+++++ SchemeName			
2.70	{{Or	+++++ Code			
2.70	Or}}	+++++ Proprietary			
2.70		+++++ Issuer			
2.70	Or}	++++ PrivateIdentification		X	
2.70		++++ DateAndPlaceOfBirth		X	
2.70		+++++ BirthDate			
2.70		+++++ ProvinceOfBirth			
2.70		+++++ CityOfBirth			
2.70		+++++ CountryOfBirth			
2.70		+++++ Other		X	
2.70		+++++ Identification			
2.70		+++++ SchemeName			
2.70	{{Or	+++++ Code			
2.70	Or}}	+++++ Proprietary			
2.70		+++++ Issuer			
2.77		+++ CreditorAgent		X	
2.77		+++ FinancialInstitutionIdentification		X	
2.77		++++ BIC		X	
2.79		+++ Creditor		X	
2.79		++++ Name		X	
2.79		++++ PostalAddress			
2.79		+++++ Country			
2.79		+++++ AddressLine		X	
2.79		++++ Identification			

Index	Or	Message Item	Applicable Usage Rules		
			ISO	EPC	NL
2.79	{Or	+++++ OrganisationIdentification		X	
2.79		+++++ BICOrBEI		X	
2.79		+++++ Other		X	
2.79		+++++ Identification			
2.79		+++++ SchemeName			
2.79	{{Or	+++++ Code			
2.79	Or}}	+++++ Proprietary			
2.79		+++++ Issuer			
2.79	Or}	+++++ PrivateIdentification		X	
2.79		+++++ DateAndPlaceOfBirth		X	
2.79		+++++ BirthDate			
2.79		+++++ ProvinceOfBirth			
2.79		+++++ CityOfBirth			
2.79		+++++ CountryOfBirth			
2.79		+++++ Other		X	
2.79		+++++ Identification			
2.79		+++++ SchemeName			
2.79	{{Or	+++++ Code			
2.79	Or}}	+++++ Proprietary			
2.79		+++++ Issuer			
2.80		+++ CreditorAccount		X	
2.80		+++ Identification		X	
2.80	{Or	+++ IBAN		X	
2.81		+++ UltimateCreditor		X	
2.81		+++ Name		X	
2.81		+++ Identification			
2.81	{Or	+++++ OrganisationIdentification		X	
2.81		+++++ BICOrBEI		X	
2.81		+++++ Other		X	
2.81		+++++ Identification			
2.81		+++++ SchemeName			

Index	Or	Message Item	Applicable Usage Rules		
			ISO	EPC	NL
2.81	{{Or	+++++ +++ Code			
2.81	Or}}	+++++++ Proprietary			
2.81		+++++++ Issuer			
2.81	Or}	+++++ PrivateIdentification		X	
2.81		+++++++ DateAndPlaceOfBirth		X	
2.81		+++++++ BirthDate			
2.81		+++++++ ProvinceOfBirth			
2.81		+++++++ CityOfBirth			
2.81		+++++++ CountryOfBirth			
2.81		+++++++ Other		X	
2.81		+++++++ Identification			
2.81		+++++++ SchemeName			
2.81	{{Or	+++++++ Code			
2.81	Or}}	+++++++ Proprietary			
2.81		+++++++ Issuer			
2.86		+++ Purpose			
2.87	{Or	+++ Code			
2.98		+++ RemittanceInformation		X	
2.99		+++ Unstructured		X	
2,100		+++ Structured		X	
2,120		+++++ CreditorReferenceInformation		X	
2,121		+++++ Type			
2,122		+++++++ CodeOrProprietary			
2,123	{Or	+++++++ Code		X	
2,125		+++++++ Issuer			X
2,126		+++++++ Reference		X	X